

5/15/98

W. W. W.

KOLLMORGEN

Motion Technologies Group

**INSTALLATION AND SERVICE MANUAL
RDP2 ANTIBACKLASH DRIVE SYSTEM
ABS24-9108
ISSUE 2**



ELECTRONIC COMPONENTS IN THIS AMPLIFIER ARE STATIC SENSITIVE. USE PROPER PROCEDURES WHEN HANDLING COMPONENT BOARDS.

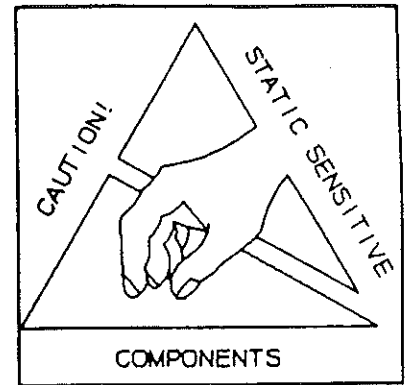

INSTALLATION AND SERVICE MANUAL RDP ANTIBACKLASH DRIVE SYSTEM

ABS24-9108
Issue 2

WARNING:

Dangerous voltages, currents, temperatures, and energy levels exist in this product and in the associated servo motor(s). Extreme caution should be exercised in the application of this equipment. Only qualified individuals should attempt to install, set-up, and operate this equipment.

WARNING:

Incorrect motor and/or resolver wiring can cause erratic or runaway motor operation. Use of factory supplied cable is highly recommended.

KOLLMORGEN

Industrial Drives

INDUSTRIAL DRIVES

201 Rock Road

Radford, VA 24141

Telephone No: (703) 639-2495

FAX No: (703) 731-0847

TABLE OF CONTENTS

	<u>PAGE</u>
1.0 INTRODUCTION	1
1.1 Model Number Scheme	2
2.0 INSTALLATION	2
2.1 Installing the RDP2 Module with ACS3 or BDS3 Amplifiers	3
2.2 Installing the RDP2 Module with BDS4 Amplifiers	3
2.3 Installing the RDP2 Module with SBD2 or SBD4 Amplifiers	3
2.4 RDP2 Board Configuration	4
3.0 PRELIMINARY CHECKS	5
3.1 ACS3 or BDS3 Motor, Resolver, and Tach (if used) Phasing	5
3.2 BDS4 Motor, Resolver, and Tach (if used) Phasing	6
3.3 SBD2 or SBD4 Motor and Tach Phasing	7
4.0 ADJUSTMENTS	8
4.1 Zero Adjustments, when Using ACS3 or BDS3 Amplifiers	9
4.2 Zero Adjustments, when Using BDS4 Amplifiers	10
4.3 Zero Adjustments, when using SBD2 or SBD4 Amplifiers	11
4.4 Tracking Adjustments	12
4.4.1 Tracking Adjustment (Manually Operated Machines)	12
4.4.2 Tracking Adjustments (N/C or C/N/C Machines)	13
4.5 BLC Adjustment	13
4.5.1 BLC Adjustment, when using ACS3 or BDS3 Amplifiers	13
4.5.2 BLC Adjustment, when using BDS4 Amplifiers	14
4.5.3 BLC Adjustment, when using SBD2 or SBD4 Amplifiers.	15
5.0 SIMPLIFIED THEORY OF OPERATION	15
6.0 TROUBLESHOOTING	16

TABLE OF FIGURES

FIGURE 1 . . . RDP2 Antibacklash Module 17

TABLE OF DRAWINGS

Outline and Dimension RDP2 Mounting Plate Assembly	C-82318	18
Schematic for RDP2 Antibacklash Board	C-82305-1	19
RDP2 Interconnect Diagram for ACS3, BDS3	C-82317	20
RDP2 Interconnect Diagram for ACS3, BDS3	C-93464	21
Cable Assembly-RDP BDS4	A-93460	22
Cable Assembly-RDP BDS4	A-93461	23
Cable Assembly-RDP BDS4	A-93462	24
Cable Assembly-RDP BDS4	A-93463	25
RDP2 Interconnect Diagram for SBD's	C-81132	26
Cable Assembly RDP	A-83245	27
Cable Assembly RDP	A-83246	28
Cable Assembly RDP	A-83247	29
Cable Assembly RDP	A-83248	30

European Community (EC) Declaration of Conformity

We, Kollmorgen Corporation Industrial Drives Division, 201 Rock Road, Radford, Virginia USA; declare under sole responsibility that this equipment is exclusively designed for incorporation in another machine. The operation of this equipment is submitted to the conformity of the machine in which it is incorporated, following the provisions of the EC Electro-Magnetic Compatibility (EMC) directive 89/392/EEC.

KOLLMORGEN

Motion Technologies Group

YOUR SINGLE SOURCE FOR SERVO SERVICE & TRAINING

On Motors and Drives Manufactured by
Kollmorgen Industrial Drives and
Kollmorgen PMI Motion Technologies

BASIC SERVICES

- ◆ Factory Representatives to support you by phone with the latest information and documentation.
- ◆ On-Site Service to support and return critical systems to operation.
- ◆ On-Site Training in *Service, Repair and Troubleshooting* with the latest documentation and information.
- ◆ Service Spares and Repairs through our Aftermarket Group.
- ◆ A complete Service Package to provide your company with a Total Service Solution.
- ◆ Fast Customer Response and Superior Quality Service.

Jerry Hill
MANAGER,
FIELD SERVICE

Fax: 540-731-0847

CALL KOLLMORGEN FOR YOUR
SERVICE AND TRAINING NEEDS

540-633-3109

Dave Conner
MANAGER
AFTERMARKET

Fax: 540-835-4167

1.0 INTRODUCTION

This manual is a supplement to motor controller manuals ACS3 Series, M-8703; BDS3 Series, M-8507; BDS4 Series, M-89032; SBD2 Series, M-8404; and SBD4 Series, M-8508. This manual covers the installation and adjustment procedures for the RDP2 antibacklash module.

The INDUSTRIAL DRIVES' RDP2 antibacklash system consists mainly of two servo motor controllers interfaced with the RDP2 antibacklash module. The servo motor controllers may be any two motor controllers bearing the same model number (refer to Figure 1).

The RDP2 antibacklash module may be interfaced with the following INDUSTRIAL DRIVES' motor controllers:

- o ACS3 Brushless AC sinewave induction synchronous servo motor controllers, rated from 6 amps to 55 amps continuous (Manual, M-8703).
- o BDS3 Brushless AC sinewave permanent magnet synchronous servo motor controllers, rated from 6 amps to 150 amps (Manuals, M-8507 or M-89111 -- 150 amp units).
- o BDS4 Brushless AC sinewave permanent magnet synchronous servo motor controllers, rated from 3 amps to 55 amps continuous (Manual M-89032).
- o SBD2 Brush type permanent magnet DC servo motor controllers, rated from 6 amps to 20 amps continuous (Manual, M-8404).
- o SBD4 Brush type permanent magnet DC servo motor controllers, rated from 30 amps to 60 amps continuous (Manual, M-8508).

These motor controllers are four quadrant bidirectional velocity loop amplifiers designed to accommodate the "regenerated" power from a decelerating "D.C." servo motor.

The RDP2 antibacklash module acts as an interface module between the N/C or C/N/C controller and the two motor controllers.

1.1 Model Number Scheme

EXAMPLE: RDP2-A-B

RDP2 Anti-Backlash System
 A Mechanical Configuration
 101 Mounting Plate Assembly
 B Test Limits Sheet

2.0 INSTALLATION

Refer to Figure 1 and Outline & Dimension Drawing C-82318.

Refer to the Mounting Section and appropriate outline and dimension drawings in the Installation and Service Manual for the servo amplifier being used. Also, attention should be given to the notes on the outline and dimension drawings for information concerning mounting details.

Refer to the Wiring Section and appropriate system wiring diagrams in the Installation and Service Manual for the servo amplifier being used. Also, attention should be given to the notes on the system wiring diagram for information concerning wiring details.

NOTE:

B Series Brushless motors have a thermostat switch wired to the resolver connector at the motor.

BR Series Brushless motors have a thermostat switch wired to the stator connector at the motor.

CAUTION:

Incorrect motor, resolver, or tach phasing can cause erratic operation, runaway, or damage to the system and machinery.

2.1 Installing the RDP2 Module with ACS3 or BDS3 Amplifiers

After mounting and wiring the two ACS3 or BDS3 servo amplifiers by referring to Installation and Service Manuals M-8703 and M-8507 or M-89111, respectively, mount the RDP2 module in the panel enclosure "along side" of the ACS3 or BDS3 amplifiers. Refer to drawings C-82318 and C-82317.

When the installation is completed, double check all wiring to ensure that it is properly done and securely connected, etc., and is connected per the appropriate manual System Wiring Diagram and RDP2 Interconnect Diagram C-82317.

2.2 Installing the RDP2 Module with BDS4 Amplifiers

After mounting and wiring the BDS4 Amplifiers by referring to the Installation and Service Manual M-89032, mount the RDP2 module in the panel enclosure "along side" of the BDS4 Amplifiers. Refer to drawings C-32318 and C-93464.

When the installation is completed, double check all wiring to insure that it is properly done and securely connected, etc., and is connected per the appropriate manual System Wiring Diagram and RDP2 Interconnect Diagram C-93464.

2.3 Installing the RDP2 Module with SBD2 or SBD4 Amplifiers

After mounting and wiring the two SBD2 or SBD4 servo amplifiers by referring to Installation and Service Manuals M-8404 or M-8508, respectively, the RDP2 module may be mounted on the wall of the panel enclosure "along side" of the SBD2 or SBD4 amplifiers or may be mounted within a frame assembly with the amplifiers. Refer to drawings C-82318 and C-81132.

When the installation is completed, double check all wiring to ensure that it is properly done and securely connected, etc., and is connected per the appropriate manual System Wiring Diagram and RDP2 Interconnect Diagram C-81132.

2.4 RDP2 Board Configuration

In order for the antibacklash system to perform properly, the direction of the motor shaft rotation must be considered. The RDP2 Board must be configured for one of the following types of applications.

- 1) The motors are mounted side-by-side so that their shafts turn in the same direction when propelling the load.



- 2) The motors are mounted end-to-end so that their shafts turn in opposite directions when propelling the load.



In order to configure the RDP2 Board with respect to the way the motors are mounted, refer to the following chart:

Direction of Motor * Shaft Rotation	BACKLASH JUMPERS		EQUALIZER JUMPERS				DIFF. INPUT JUMPERS	
	J3	J4	J16	J17	J8	J9	J22	J23
Motor Shafts Turn in Same Direction	OUT	IN	OUT	IN	OUT	IN	OUT	IN
Motor Shafts Turn in Opposite Direction	IN	OUT	IN	OUT	IN	OUT	IN	OUT

* The RDP2 Board has been configured prior to shipment according to the TEST LIMITS SHEET for the system. Refer to the model number scheme in Section 1.1.

The interface connections VLO, GND, VLI, and ILI on the SBD2 amplifiers are made via the RDP connector 34, located on the small SBD2-COMP2 compensation card. These same interface connections on the SBD4 amplifiers are made via the RDP connector 6, located on the main board just behind the I/O terminal block. When the installation is completed, double check all wiring to ensure that it is properly done and securely connected, etc., and is connected per the appropriate manual System Wiring Diagram and RDP2 Interconnect Diagram C-81132.

3.0 PRELIMINARY CHECKS

Once the RDP2 system is installed on the machine according to the appropriate Interconnect Diagram, correct motor phasing should be confirmed.

3.1 ACS3 or BDS3 Motor, Resolver, and Tach (if used) Phasing

Refer to Interconnect Diagram C-82317.

If the motor stator, resolver, and tach (if used) are connected according to the System Wiring Diagram in manual M-8703 or M-8507 (or M-89111, 150 amp unit) for the ACS3 or BDS3 amplifiers, respectively, the phasing sequence will automatically be correct. There are no other wiring options. Also refer to Interconnect Diagram C-82317.

The input I/O Connector 210 on the ACS3 and BDS3 amplifiers are interfaced with the RDP2 module according to Interconnect Diagram C-82317.

Begin the initial start-up by enabling only one amplifier at a time. Check the operation of the servo loops by exercising the system at low speeds to confirm its stability, etc. To check one of the amplifiers for proper operation, do the following:

- 1) Remove connectors 10 and 37 from the RDP2 module.
- 2) Open the Remote Inhibit circuit of one of the amplifiers.
- 3) Exercise the remaining "enabled" amplifier at low speeds to confirm proper operation.
- 4) Disable the active amplifier by performing 2) above and check the other amplifier.

Reinstall Connectors 10 and 37 back on the RDP2. If after applying power and the machine is commanded to move but moves in the wrong direction, remove power. Change the direction jumpers located on the Compensation Board as follows:

If the amplifiers are model ACS3, go to step 1.

If the amplifiers are model BDS3, go to step 2.

STEP 1: Remove the ACS3-COMP2 Compensation Board from the ACS3 amplifiers. Notice the INVERTING and NON-INVERTING jumpers J66 and J67 on the compensation boards. Only one of the two jumpers will be installed. Remove the jumper installed. Add the jumper originally missing. This will allow the motor to move the machine in the desired direction with respect to the input signal polarity. If necessary, make this change to both amplifier #1 and #2 compensation boards.

STEP 2: Remove the ACS3-COMP1 Compensation Board from the BDS3 amplifiers. Notice the INVERTING and NON-INVERTING jumpers J10 and J11 on the compensation boards. Only one of the two jumpers will be installed. Remove the jumper installed. Add the jumper originally missing. This will allow the motor to move the machine in the desired direction with respect to the input signal polarity. If necessary, make this change to both amplifier #1 and #2 compensation boards.

3.2 BDS4 Motor, Resolver, and Tach (if used) Phasing

Refer to Interconnect Diagram C-93464.

If the motor stator, resolver, and tach (if used) are connected according to the System Wiring Diagram in Manual M-89032, the phasing sequence will automatically be correct. There are no other wiring options. Also refer to Interconnect Diagram C-93464.

The input I/O Connector C₁ and the logic supply Connector C₃ on the BDS4 are interfaced with the RDP2 module according to Interconnect Diagram C-93464.

Begin the initial start-up by enabling only one amplifier at a time. Check the operation of the servo loops by exercising the system at low speeds to confirm its stability, etc. To check the amplifiers, do the following:

- 1) Remove Connectors 10 and 37 from the RDP2 module.
- 2) Open the Enable circuit of one of the BDS4 amplifiers.
- 3) Exercise the remaining "enabled" BDS4 at low speeds to confirm proper operation.
- 4) Disable the active BDS4 by performing #2 above and check the other BDS4.

Reinstall Connector 10 and 37 back on the RDP2.

If after applying power and the machine is commanded to move but moves in the wrong direction, remove power. Change the direction of movement by interchanging the input Hi and Lo signals at Connector 37-19 and 20 of the RDP2 module.

3.3 SBD2 or SBD4 Motor and Tach Phasing

Refer to Interconnect Diagram C-81132.

With the primary power off, place the red lead of a D.C. voltmeter on TACH HI of Amplifier #1. Place the black lead of the meter on TACH LO or TP-GND. Have an assistant rotate the shaft of Motor #1 C.W. as viewed by looking into the large end of the motor shaft. The meter should deflect in the POSITIVE direction; if not, reverse the tach leads and repeat the test. Place the red lead of the D.C. voltmeter on MOTOR HI of Amplifier #1. Place the black lead on MOTOR LO. Have an assistant rotate the shaft of Motor #1 C.W. The meter should deflect in the NEGATIVE direction; if not, reverse the motor leads (at the motor) and repeat the test.

Place the red lead of the meter on TACH HI of Amplifier #2 and the black lead on TACH Lo or TP-GND. Have an assistant rotate the shaft of Motor #2 C.W. The meter should deflect in the NEGATIVE direction or opposite to that of Tach #1; if not, reverse the tach leads and repeat the test. Place the red lead of the voltmeter on MOTOR HI of Amplifier #2. Place the black lead on MOTOR LO. Have an assistant rotate the shaft of Motor #2 C.W. The meter should deflect in the POSITIVE direction; if not, reverse the motor leads (at the motor) and repeat the test.

Notice that the polarities of the tachs are opposite with respect to the polarities of the motors and the polarities of the two motors and tachs are opposite with respect to each other.

After applying power and the machine is commanded to move, if the machine moves in the wrong direction, remove power. Reverse both sets of tach and motor leads to obtain the correct direction of motor shaft rotation for the desired movement of the machine. Begin the initial start-up by enabling only one amplifier at a time. Check the operation of the servo loops by exercising the system at low speeds to confirm its stability, etc. To check the amplifiers for proper operation, do the following:

- 1) Remove connectors 10 and 37, of the amplifier being disabled, from the RDP2 module.
- 2) Open the Remote Inhibit circuit of one of the amplifiers.
- 3) Exercise the remaining "enabled" amplifier at low speeds to confirm proper operation.
- 4) Disable the active amplifier by performing 2) above and check the other amplifier.

Reinstall Connectors 10 and 37 back on the RDP2.

4.0 ADJUSTMENTS

Refer to Figure 1. The RDP2 system may be utilized in either of two major applications:

- 1) As an antibacklash system where the motors are mounted on the same propelling member of a machine to take-up backlash (rack and pinion).
- 2) As a split servo system where backlash take-up is not utilized but rather where the motors are mounted on separate propelling members of a machine to achieve tracking of the two members (twin ball or acme screws).

When the RDP2 system is used in split-servo applications utilizing twin ball or acme screws, the BLC (Back Lash Current) adjustment (described in Section 4.5) must be set for zero backlash current.

The adjustments should be checked prior to putting the system into operation. If any adjustment has to be made other than those contained in this RDP2 manual, refer to the ADJUSTMENT section of the appropriate servo amplifier manual.

4.1 Zero Adjustments, when Using ACS3 or BDS3 Amplifiers

REMOVE POWER.

Temporarily remove the Connector 37 and 10 from the RDP2 module. Remove the INPUT REFF HI and INPUT REFF LO input wires from pins 14 and 15 on Connector 210 of Amplifiers #1 and #2. Place a jumper from pins 14 to 15 on Connector 210 of both amplifiers. Remove the REMOTE INHIBIT wire from Connector 210-8 of Amplifier #2. **Amplifier #2 must remain inhibited.** With a D.C. voltmeter, monitor pin 19 with respect to pin 10 on Connector 210 of Amplifier #1.

APPLY POWER.

Adjust the ZERO pot, located on the Compensation Board, of Amplifier #1 for zero volts on the meter or for zero motor movement.

REMOVE POWER.

Reconnect the REMOTE INHIBIT wire to Connector 210-8 of Amplifier #2. Remove the REMOTE INHIBIT wire from Connector 210-8 of Amplifier #1. **Amplifier #1 must remain inhibited.** With a D.C. voltmeter, monitor pin 19 with respect to pin 10 on Connector 210 of Amplifier #2. Apply power. Adjust the ZERO pot, located on the Compensation Board, of Amplifier #2 for zero volts on the meter or for zero motor movement. Remove power. Remove the jumpers from pins 14 to 15 on the I/O Connector of Amplifiers #1 and #2. Reconnect the input wires to pins 14 and 15 on the I/O Connector of both amplifiers.

Remove the REMOTE INHIBIT wire from Connector 210-8 of Amplifier #2. With a D.C. voltmeter, monitor TP348 with respect to TP350 (common) on the Motor Control Board of Amplifier #1. Apply power. **Both amplifiers should remain inhibited.** Adjust Pot 49 on the Base Drive Board of Amplifier #1 for zero volts ± 10 mv. Move the voltmeter to TP386 on the Motor Control Board of Amplifier #1. Adjust Pot 54 on the Base Drive Board for Amplifier #1 for zero volts ± 10 mv. Recheck TP348 and TP386.

REMOVE POWER.

With a D.C. voltmeter, monitor TP348 with respect to TP-350 on the Motor Control Board of Amplifier #2. Apply power. **Both amplifiers should remain inhibited.** Adjust Pot 49 on the Base Drive Board of Amplifier #2 for zero volts ± 10 mv. Move the voltmeter to TP386 on the Motor Control Board of Amplifier #2. Adjust Pot 54 on the Base Drive Board of Amplifier #2 for zero volts ± 10 mv. Recheck TP348 and TP386.

REMOVE POWER.

Reconnect Connectors 37 and 10 to the RDP2 module. Temporarily remove the DIFF HI and DIFF LO input wires from Pins 19 and 20 of Connector 37. Place a jumper from Pin 19 to 20. With a D.C. voltmeter, monitor TP57 with respect to TP55 on the RDP2 module.

APPLY POWER.

Adjust Pot 73 on the RDP2 module for zero volts. Move the voltmeter to TP50 on the RDP2 module. Adjust Pot 75 for zero volts.

REMOVE POWER.

Remove jumper between pins 19 and 20 of Connector 37 on the RDP2 module. Remove the voltmeter. Reconnect the DIFF HI and DIFF LO input wires to pin 19 and 20.

APPLY POWER.

Enable both amplifiers and command zero speed. If there is motor creep present (manifested by the presence of "standing error" at the input of the RDP2 module), adjust Pot 73 on the RDP2 module to bring the motor to zero speed and/or the "standing error" to zero.

4.2 Zero Adjustments, when Using BDS4 Amplifiers

REMOVE POWER.

Temporarily remove mating Connectors 37 and 10 from the RDP2 module. Connect a jumper between Pin 16 and 17 of Mating Connector 37. Connect a jumper between Pin 8 and 9 of Mating Connector 10. Open the ENABLE circuit of Amplifier #2. **AMPLIFIER #2 MUST REMAIN INHIBITED.**

With a D.C. voltmeter, monitor TP84-1 with respect to TP84-3 on amplifier #1 (for amplifiers rated 3 amps to 20 amps continuous) -- for amplifiers rated 30 amps to 55 amps, monitor TC1-1 with respect to TC1-3.

APPLY POWER.

Adjust the Balance Pot, located in the front of amplifier #1, for zero volts on the meter.

REMOVE POWER.

Close the ENABLE circuit of Amplifier #2. Open the ENABLE circuit of Amplifier #1. **AMPLIFIER #1 MUST REMAIN INHIBITED.**

With a D.C. Voltmeter, monitor TP84-1 with respect to TP84-3 on amplifier #2 (for amplifiers rated 3 amps to 20 amps continuous) -- for amplifiers rated 30 amps to 55 amps, monitor TC1-1 with respect to TC1-3.

APPLY POWER.

Adjust the Balance Pot, located in the front of amplifier #2, for zero volts on the meter.

REMOVE POWER.

Remove jumpers from mating Connector 37 and 10. Install mating Connectors 37 and 10 back onto the RDP2 module. Temporarily remove the DIFF HI and DIFF LO input wires from Pins 19 and 20 of Connector 37. Place a jumper from Pin 19 to 20.

With a D.C. voltmeter, monitor TP57 with respect to TP55 on the RDP2 module. Open the ENABLE circuits of both amplifiers. **BOTH AMPLIFIERS MUST REMAIN INHIBITED.**

APPLY POWER.

Adjust Pot 73 on the RDP2 module for zero volts. Move the voltmeter to TP59 on the RDP2 module. Adjust Pot 75 for zero volts.

REMOVE POWER.

Remove jumper between Pin 19 and 20 of Connector 37 on the RDP2 module. Reconnect the DIFF HI and DIFF LO input wires to Pin 19 and 20. Remove the D.C. voltmeter.

APPLY POWER.

Close the ENABLE circuits of both amplifiers. If there is motor creep present (manifested by the presence of "standing error" at the input of the RDP2 module), adjust Pot 73 on the RDP2 module to bring the "standing" error to zero.

4.3 Zero Adjustments, when using SBD2 or SBD4 Amplifiers

REMOVE POWER.

Temporarily remove the DIFF HI and DIFF LO input wires from pins 19 and 20 of Connector 37 on the RDP2 module. Place a jumper from pins 19 to 20. Place a jumper on the I/O Connector (back side) from pins 14 to 15 of Amplifier #1 and #2. With a D.C. voltmeter monitor pin 3 with respect to pin 2 on the I/O Connector of Amplifier #1.

APPLY POWER.

Close the ENABLE circuit of Amplifier #1 only. **Amplifier #2 must remain inhibited.** Adjust ZERO Pot 6 on the SBD2 main board, or ZERO Pot 46 on the Compensation Board of the SBD4 for zero volts on the meter or for zero motor movement. Open the inhibit circuit of Amplifier #1.

REMOVE POWER.

With a D.C. voltmeter, monitor pin 3 with respect to pin 2 on the I/O Connector of Amplifier #2. Apply power. Close the ENABLE circuit of Amplifier #2 only. **Amplifier #1 must remain inhibited.** Adjust Pot 6 on the SBD2 main board, or ZERO Pot 46 on the Compensation Board of the SBD4 for zero volts on the meter or for zero motor movement.

REMOVE POWER.

Remove the jumpers from pins 14 to 15 on the I/O Connector of Amplifiers #1 and #2.

With a D.C. voltmeter, monitor TP57 with respect to TP55 on the RDP2 module. Apply power. Open the ENABLE circuits of Amplifier #1 and #2 to inhibit both amplifiers. Adjust Pot 73 on the RDP2 module for zero volts. Move the voltmeter to TP59 on the RDP2 module. Adjust Pot 75 for zero volts.

REMOVE POWER.

Remove jumper between pins 19 and 20 of Connector 37 on the RDP2 module. Remove the voltmeter. Reconnect the DIFF HI and DIFF LO input wires to pin 19 and 20. Apply power. Enable both amplifiers and command zero speed. If there is motor creep present (manifested by the presence of "standing error" at the input of the RDP2 module), adjust Pot 73 on the RDP2 module to bring the motor to zero speed and/or the "standing error" to zero.

4.4 Tracking Adjustments

In order for the two motors to accelerate together, reach their constant velocities together and decelerate together; they must be able to "track" each other.

4.4.1 Tracking Adjustment (Manually Operated Machines)

REMOVE POWER.

Turn the SPEED, COMMAND SCALE or SCALE FACTOR pots on Amplifier #1 and #2 75% clockwise (C.W.).

Turn Pot 72 on the RDP2 Board 100% fully counterclockwise (C.C.W.).

With a D.C. voltmeter, monitor Pin 20 with respect to Pin 19 on Connector 37 of the RDP2 module.

APPLY POWER and enable the amplifiers.

The input signal for maximum speed should not exceed ± 8 VDC. However, for the present apply only ± 2 VDC input signal as monitored by the meter. There should be no movement from the machine.

Move the meter and monitor TP59 with respect to TP55 on the RDP2 Board.

Turn Pot 72 on the RDP2 module C.W. until the machine is running at 25% of maximum speed.

Adjust the SPEED, COMMAND SCALE, or SCALE FACTOR pot on

Amplifier #2 for zero volts on the meter. ± 0.5 VDC.

4.4.2 Tracking Adjustments (N/C or C/N/C Machines)

REMOVE POWER.

Turn the SPEED, COMMAND SCALE, or SCALE FACTOR pots on Amplifier #1 and #2 75% fully clockwise (C.W.).

Turn Pot 72 on the RDP2 module 50% clockwise (C.W.).

With a D.C. voltmeter, monitor TP59 with respect to TP55 on the RDP2 module. Apply power. Command a slow "feed rate" speed and notice the "Following Error" displayed on the position loop controller monitor.

Adjust Pot 72 on the RDP2 module for the proper amount of "Following Error" for the speed the machine is running at.

Adjust the SPEED, COMMAND SCALE, or SCALE FACTOR pot on Amplifier #2 for zero volts on the meter (± 0.5 VDC).

Run the machine at maximum speed. If necessary adjust Pot 72 on the RDP2 module to achieve the proper amount of "Following Error" as displayed on the monitor. Also, if necessary, readjust the SPEED, COMMAND SCALE, or SCALE FACTOR pot on Amplifier #2 for zero volts on the meter (± 0.5 VDC).

4.5 BLC Adjustment

The BACKLASH CURRENT (BLC) Adjustment allows a means by which a predetermined amount of offset can be injected into the current loop summing junctions of the two servo amplifiers, to cause the motors to develop "windup" torques toward or away from each other, for the purpose of backlash take up in gear boxes or rack and pinion drives.

4.5.1 BLC Adjustment, when using ACS3 or BDS3 Amplifiers

REMOVE POWER.

Place a jumper from pin 5 (SUM2) to pin 6 (VEERROR) of Connector 210 for both amplifiers.

With a D.C. voltmeter monitor pin 18 (I MON) with respect to pin 10 (A COM) of Amplifier #1.

APPLY POWER.

Adjust Pot 74 on the RDP2 Board for the amount of backlash current needed to remove the backlash and note the voltage recorded by the meter. Refer to the SIGNAL INPUTS AND MODES OF OPERATION Section of the ACS3 or BDS3 Installation and Service Manual for the current scale factor in AMPS/VOLT at the I MON output at pin 18. Once the I MON current scale factor in AMPS/VOLT is known, the backlash current may be determined.

The amount of "take-up" current needed will vary from application to application and is usually determined by trial and error. Since the amount of backlash current used is deducted (considered a loss) from the continuous current rating of the motor, only the amount of backlash current necessary should be utilized.

REMOVE POWER.

Remove the jumpers and meter. If after the adjustment made, the backlash take-up is inadequate, repeat the adjustment procedure for increased backlash current.

4.5.2 BLC Adjustment, when using BDS4 Amplifiers

Refer to System Wiring Diagram C-93464.

REMOVE POWER.

Remove the wire from Connector 37-12 of the RDP2 Board and temporarily connect it to Connector 37-14 (with the wire already there).

Remove the wire from Connector 10-4 of the RDP2 Board and temporarily connect it to Connector 10-6 (with the wire already there).

For BDS4 amplifiers rated 3 amps to 20 amps continuous, monitor TP84-2 with respect to TP84-3 of Amplifier #1. For BDS4 Amplifiers rated 30 amps to 55 amps continuous, monitor TC1-2 with respect to TC1-3 of Amplifier #1.

APPLY POWER.

Adjust Pot 74 on the RDP2 Board for the amount of backlash current needed to remove the backlash and note the voltage recorded by the meter. The current scale factor at TP84-2 or TPTC1-2 is $8V = \text{Peak}$

RMS current rating of the BDS4.

The amount of "take-up" current needed will vary from application to application and is usually determined by trial and error. Since the amount of backlash current used is deducted (considered a loss) from the continuous current rating of the motor only the amount of backlash current necessary should be utilized.

4.5.3 BLC Adjustment, when using SBD2 or SBD4 Amplifiers

REMOVE POWER.

Place a jumper from Pin 12 (TORQUE HOLD) to pin 1 (COMMON) on the backside of Connector I/O of both amplifiers.

With a D.C. voltmeter, monitor pin 4 (I MON) with respect to pins 1 or 9 at the backside of Connector I/O of Amplifier #1. Apply power. Adjust Pot 74 on the RDP2 module for the amount of backlash current needed to remove the backlash and note the voltage recorded by the meter. Refer to the SIGNAL INPUTS AND MODES OF OPERATION Section of the SBD2 and SBD4 Installation and Service Manual for the current scale factor in AMPS/VOLT at the I MON output at pin 4. Once the I MON current scale factor in AMPS/VOLT is known the backlash current may be determined.

The amount of "take-up" current needed will vary from application to application and is usually determined by trial and error. Since the amount of backlash current used is deducted (considered a loss) from the continuous current rating of the motor, only the amount of backlash current necessary should be utilized.

REMOVE POWER.

Remove the jumpers and meter. If, after the adjustment is made, the backlash take-up is inadequate, repeat the adjustment procedure for increased backlash current.

5.0 SIMPLIFIED THEORY OF OPERATION

The RDP2 Antibacklash Module has the necessary circuitry to receive a single input command from N/C, C/N/C or manually controlled machines and provide output command signals of proper polarity to the inputs of two servo motor amplifiers.

The equalization of the two motor currents is accomplished through an equalizer circuit. This circuit monitors the velocity error signals of both motor controllers and automatically corrects the motor speeds, as well as their current, allowing them to work together. When the motors are accelerated to high speeds, the equalizer circuit ensures that harmony prevails between the two motors as when running at constant velocity. Both motors are capable of accelerating in either direction so as to not present high inertial loads to the opposite motor when accelerating the load. If necessary, under heavy peak current situations, the "following" motor will cross the backlash in a controlled fashion and help the "driving" motor accelerate the load.

With the RDP2 system, backlash can be eliminated from a machine while at the same time being able to accelerate and decelerate at high traverse rates with both motors actively contributing to machine efficiency and performance.

The RDP2 Board supplies an offset current to the inputs of the current loop circuits of each motor controller causing the motors to develop wind-up torque toward or away from each other to either "compress" or "stretch" a gear box or rack, removing unwanted lost motion (backlash). The desired amount of wind-up offset is inserted equally into the summing functions of both current loop circuits by a single adjustment. This provides a stable high stiffness servo loop for N/C, C/N/C, or manual machine tools or other machinery requiring antibacklash "take-up" capability.

6.0 TROUBLESHOOTING

It is recommended that the amplifiers be checked out independently when troubleshooting the RDP2 Antibacklash system. This can be accomplished by doing the following:

1. Remove Connectors 10 and 37 from the RDP2 module.
2. Remove the motor leads and inhibit the amplifier not being checked.
3. Refer to the troubleshooting section of the appropriate amplifier Installation and Service Manual.
4. Refer to RDP2 schematic C-82305-1.

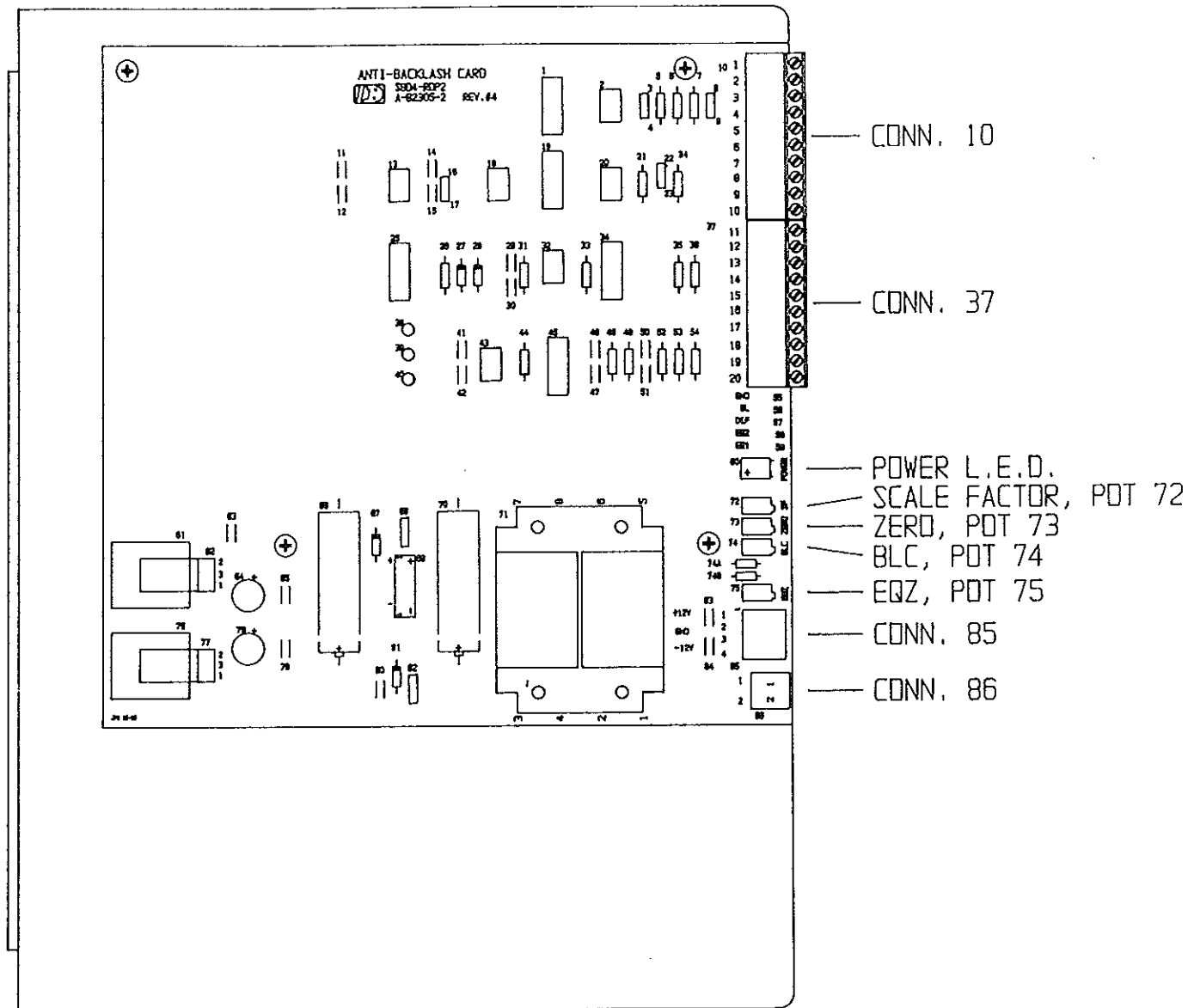

RDP2 ANTIBACKLASH MODULE
FIGURE 1

ALL DIMENSIONS ARE IN INCHES UNLESS OTHERWISE SPECIFIED
 DATE: 01-11-61
 DRAWING NO: 82318
 REVISIONS: 1, 2, 3, 4, 5, 6, 7, 8, 9, 10, 11, 12, 13, 14, 15, 16, 17, 18, 19, 20, 21, 22, 23, 24, 25, 26, 27, 28, 29, 30, 31, 32, 33, 34, 35, 36, 37, 38, 39, 40, 41, 42, 43, 44, 45, 46, 47, 48, 49, 50, 51, 52, 53, 54, 55, 56, 57, 58, 59, 60, 61, 62, 63, 64, 65, 66, 67, 68, 69, 70, 71, 72, 73, 74, 75, 76, 77, 78, 79, 80, 81, 82, 83, 84, 85, 86, 87, 88, 89, 90, 91, 92, 93, 94, 95, 96, 97, 98, 99, 100

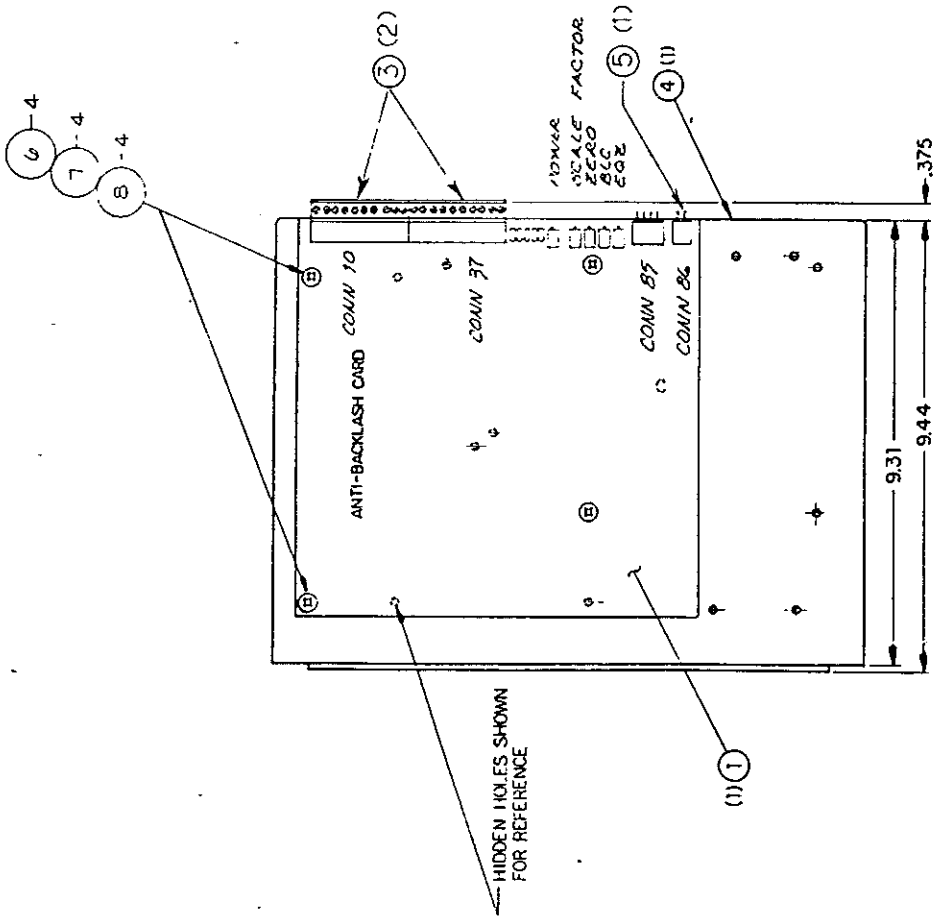

INDUSTRIAL DRIVES		INDUSTRIAL DRIVES	
RDP2 MOUNTING PLATE ASSY & OUTLINE & DIMENSION		RDP2 MOUNTING PLATE ASSY & OUTLINE & DIMENSION	
NO	SCR NO.	DATE	BY
1	2	1-16-61	V. J. LILL
2	3	1-16-61	V. J. LILL
3	4	1-16-61	V. J. LILL
4	5	1-16-61	V. J. LILL
5	6	1-16-61	V. J. LILL
6	7	1-16-61	V. J. LILL
7	8	1-16-61	V. J. LILL
8	9	1-16-61	V. J. LILL
9	10	1-16-61	V. J. LILL
10	11	1-16-61	V. J. LILL
11	12	1-16-61	V. J. LILL
12	13	1-16-61	V. J. LILL
13	14	1-16-61	V. J. LILL
14	15	1-16-61	V. J. LILL
15	16	1-16-61	V. J. LILL
16	17	1-16-61	V. J. LILL
17	18	1-16-61	V. J. LILL
18	19	1-16-61	V. J. LILL
19	20	1-16-61	V. J. LILL
20	21	1-16-61	V. J. LILL
21	22	1-16-61	V. J. LILL
22	23	1-16-61	V. J. LILL
23	24	1-16-61	V. J. LILL
24	25	1-16-61	V. J. LILL
25	26	1-16-61	V. J. LILL
26	27	1-16-61	V. J. LILL
27	28	1-16-61	V. J. LILL
28	29	1-16-61	V. J. LILL
29	30	1-16-61	V. J. LILL
30	31	1-16-61	V. J. LILL
31	32	1-16-61	V. J. LILL
32	33	1-16-61	V. J. LILL
33	34	1-16-61	V. J. LILL
34	35	1-16-61	V. J. LILL
35	36	1-16-61	V. J. LILL
36	37	1-16-61	V. J. LILL
37	38	1-16-61	V. J. LILL
38	39	1-16-61	V. J. LILL
39	40	1-16-61	V. J. LILL
40	41	1-16-61	V. J. LILL
41	42	1-16-61	V. J. LILL
42	43	1-16-61	V. J. LILL
43	44	1-16-61	V. J. LILL
44	45	1-16-61	V. J. LILL
45	46	1-16-61	V. J. LILL
46	47	1-16-61	V. J. LILL
47	48	1-16-61	V. J. LILL
48	49	1-16-61	V. J. LILL
49	50	1-16-61	V. J. LILL
50	51	1-16-61	V. J. LILL
51	52	1-16-61	V. J. LILL
52	53	1-16-61	V. J. LILL
53	54	1-16-61	V. J. LILL
54	55	1-16-61	V. J. LILL
55	56	1-16-61	V. J. LILL
56	57	1-16-61	V. J. LILL
57	58	1-16-61	V. J. LILL
58	59	1-16-61	V. J. LILL
59	60	1-16-61	V. J. LILL
60	61	1-16-61	V. J. LILL
61	62	1-16-61	V. J. LILL
62	63	1-16-61	V. J. LILL
63	64	1-16-61	V. J. LILL
64	65	1-16-61	V. J. LILL
65	66	1-16-61	V. J. LILL
66	67	1-16-61	V. J. LILL
67	68	1-16-61	V. J. LILL
68	69	1-16-61	V. J. LILL
69	70	1-16-61	V. J. LILL
70	71	1-16-61	V. J. LILL
71	72	1-16-61	V. J. LILL
72	73	1-16-61	V. J. LILL
73	74	1-16-61	V. J. LILL
74	75	1-16-61	V. J. LILL
75	76	1-16-61	V. J. LILL
76	77	1-16-61	V. J. LILL
77	78	1-16-61	V. J. LILL
78	79	1-16-61	V. J. LILL
79	80	1-16-61	V. J. LILL
80	81	1-16-61	V. J. LILL
81	82	1-16-61	V. J. LILL
82	83	1-16-61	V. J. LILL
83	84	1-16-61	V. J. LILL
84	85	1-16-61	V. J. LILL
85	86	1-16-61	V. J. LILL
86	87	1-16-61	V. J. LILL
87	88	1-16-61	V. J. LILL
88	89	1-16-61	V. J. LILL
89	90	1-16-61	V. J. LILL
90	91	1-16-61	V. J. LILL
91	92	1-16-61	V. J. LILL
92	93	1-16-61	V. J. LILL
93	94	1-16-61	V. J. LILL
94	95	1-16-61	V. J. LILL
95	96	1-16-61	V. J. LILL
96	97	1-16-61	V. J. LILL
97	98	1-16-61	V. J. LILL
98	99	1-16-61	V. J. LILL
99	100	1-16-61	V. J. LILL

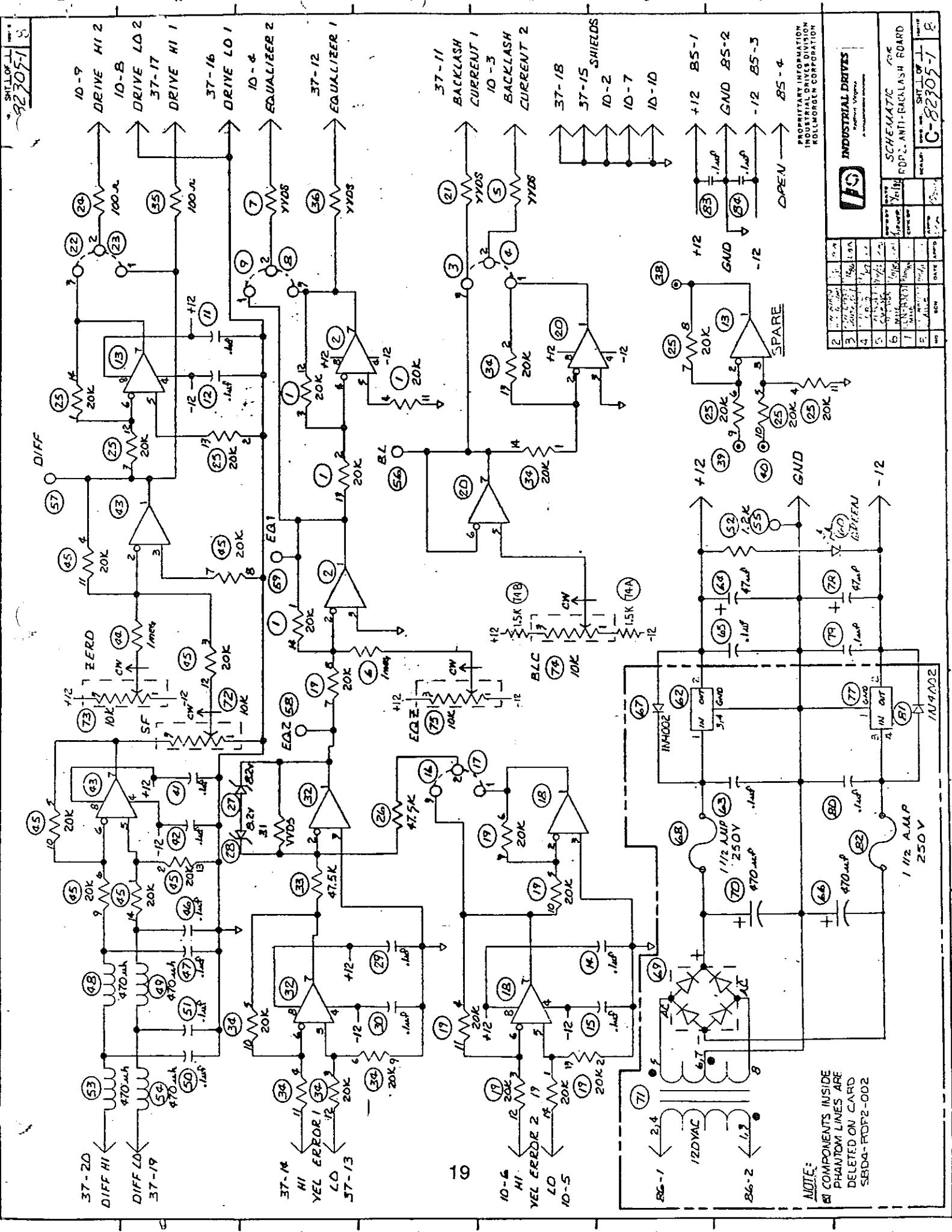

NOTE:
 COMPONENTS INSIDE
 PHANTOM LINES ARE
 DELETED ON CARD
 SERDA-RDF2-002

INDUSTRIAL DRIVES
 PROPRIETARY INFORMATION
 INDUSTRIAL DRIVES DIVISION
 HOLLANDER CORPORATION

SCHEMATIC
 RDP2-ANTI-BACKLASH BOARD

REV. 1
 DATE 1/1/80
 DRAWN BY
 CHECKED BY
 APPROVED BY

INDUSTRIAL DRIVES
 11000 W. 14TH AVE.
 MINNEAPOLIS, MN 55440
 TEL: 612-835-1000
 FAX: 612-835-1001

INDUSTRIAL DRIVES
 11000 W. 14TH AVE.
 MINNEAPOLIS, MN 55440
 TEL: 612-835-1000
 FAX: 612-835-1001

INDUSTRIAL DRIVES
 11000 W. 14TH AVE.
 MINNEAPOLIS, MN 55440
 TEL: 612-835-1000
 FAX: 612-835-1001

INDUSTRIAL DRIVES
 11000 W. 14TH AVE.
 MINNEAPOLIS, MN 55440
 TEL: 612-835-1000
 FAX: 612-835-1001

REV.	DATE	BY	CHKD.	APP'D.
1				
2				
3				
4				
5				
6				
7				
8				

C-82305-1

BDS3, ACS3

RDP2-101

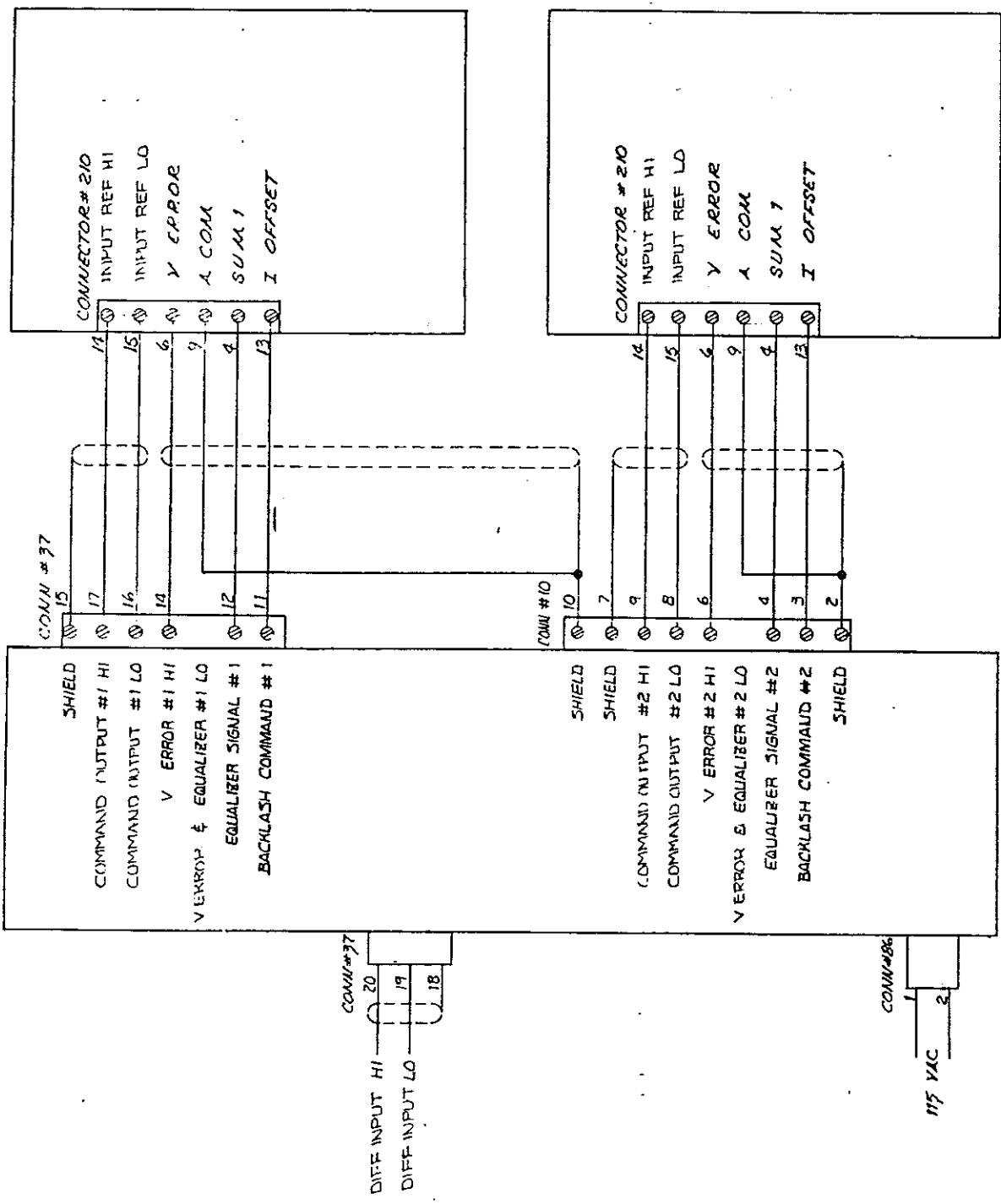

3	83874	QVENS	219	27
2	81937	TDC	200	40
REV. ECU NUMBER, INITIAL DIE APD				
 INLAND MOTOR INDUSTRIAL DRIVE DIVISION COLLINGSWOOD, CALIFORNIA 95608-1000				
RDP2 INTERCONNECT DIAGRAM				
FOR ACS3, BDS3				
DATE	BY	SCALE	REV	NO.
				3

RDP2-101

BDS 4

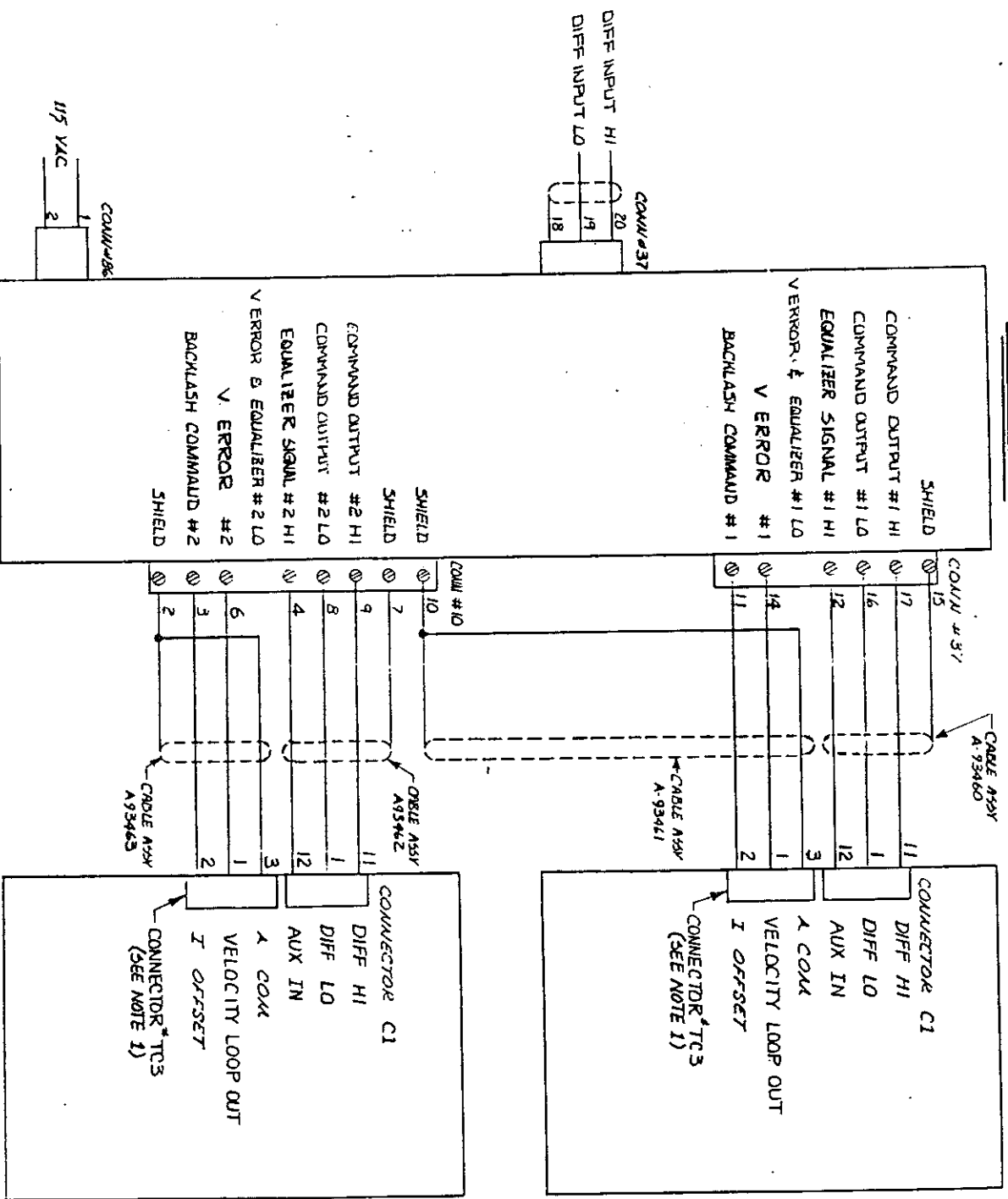

NOTES:
1. ON BDS4-MC1 CONNECTOR TC3 IS COMPONENT #B,
ON BDS4-MC2 CONNECTOR TC3 IS COMPONENT #119,
ON BDS4-MC4 CONNECTOR TC3 IS COMPONENT #250.

2	84785	929 92	1/8/82
TYPE	REV. NO.	DATE	APPRO.
INDUSTRIAL DRIVERS			
RDP2 INTERCONNECT DIAGRAM			
BDS 4			
SHEET 1 OF 2			
13464			
2			

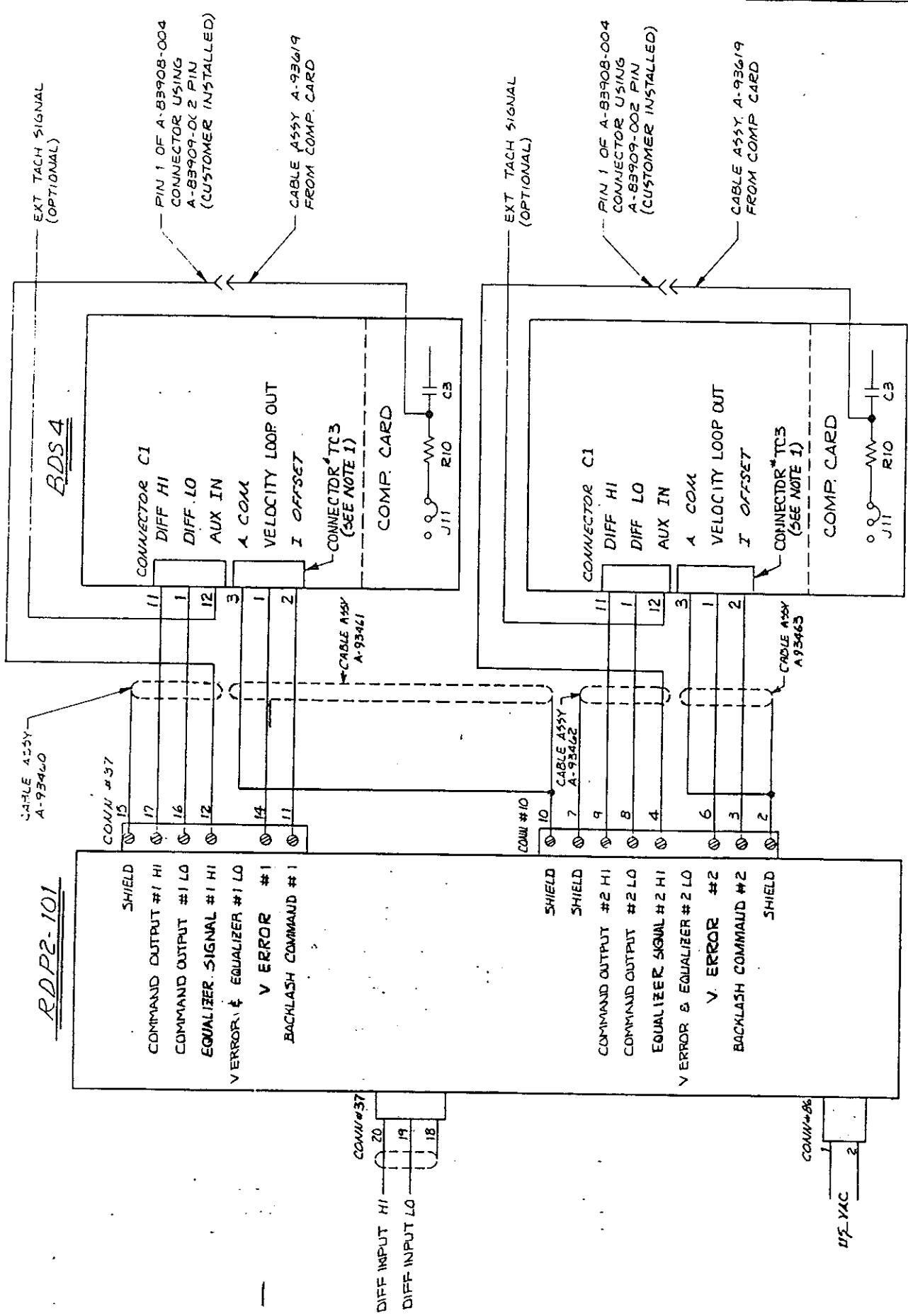

NOTES:

- ON BDS4-MC1 CONNECTOR TC3 IS COMPONENT #8,
ON BDS4-MC2 CONNECTOR TC3 IS COMPONENT #119,
ON BDS4-MC4 CONNECTOR TC3 IS COMPONENT #250.

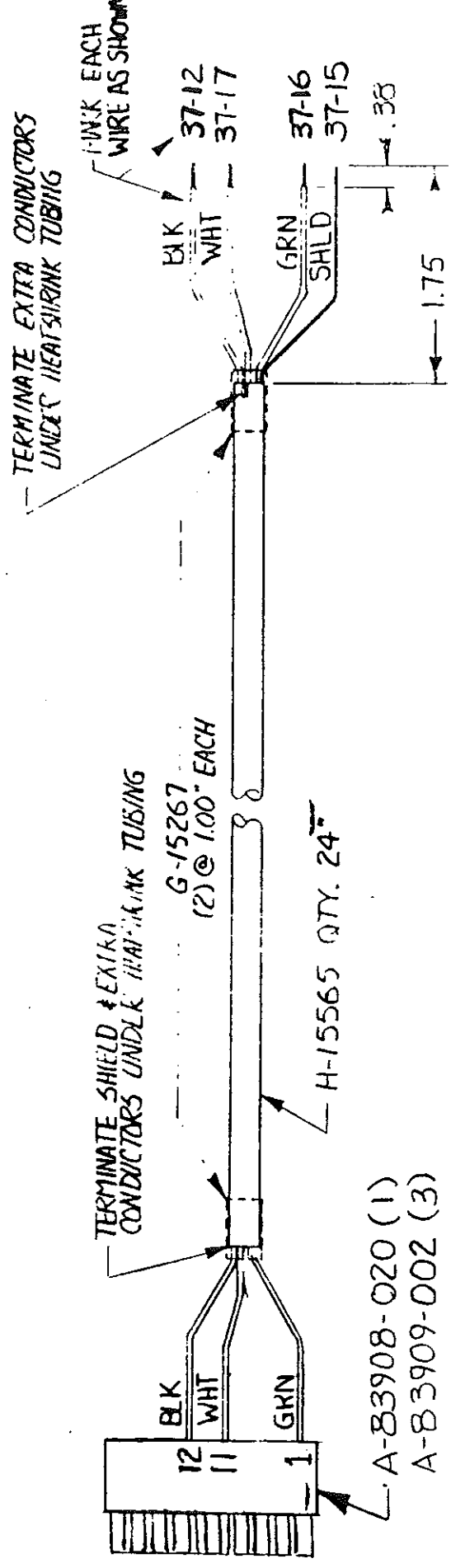

- ↖ A-83908-020 (1)
- ↖ A-83909-002 (3)

NOTES:
 1. MARK CABLE WITH DRAWING & CURRENT ISSUE NUMBER.

 INDUSTRIAL DRIVELS Radford, Virginia A HOLLANDER DIVISION		CABLE ASSY-RDP BDS54		SCALE: DWG. NO. A-93460	
		DWG. NO. A-93400 ISSUE 1		DATE: 3-6-92 DWN BY: EWR CHK BY: APPD BY: <i>SM</i> 3-16-92	
UNLESS OTHERWISE SPECIFIED XX DEC. PLACES ±.015 XXX DEC. PLACES ±.008 ANG. DIM. ±.1°		ISS: ECN NO. DATE APPD ISS ECN NO. DATE APPD		DO NOT SCALE DWG. USE DIMENSIONS ONLY ALL DIMENSIONS ARE INCHES UNLESS OTHERWISE SPECIFIED	

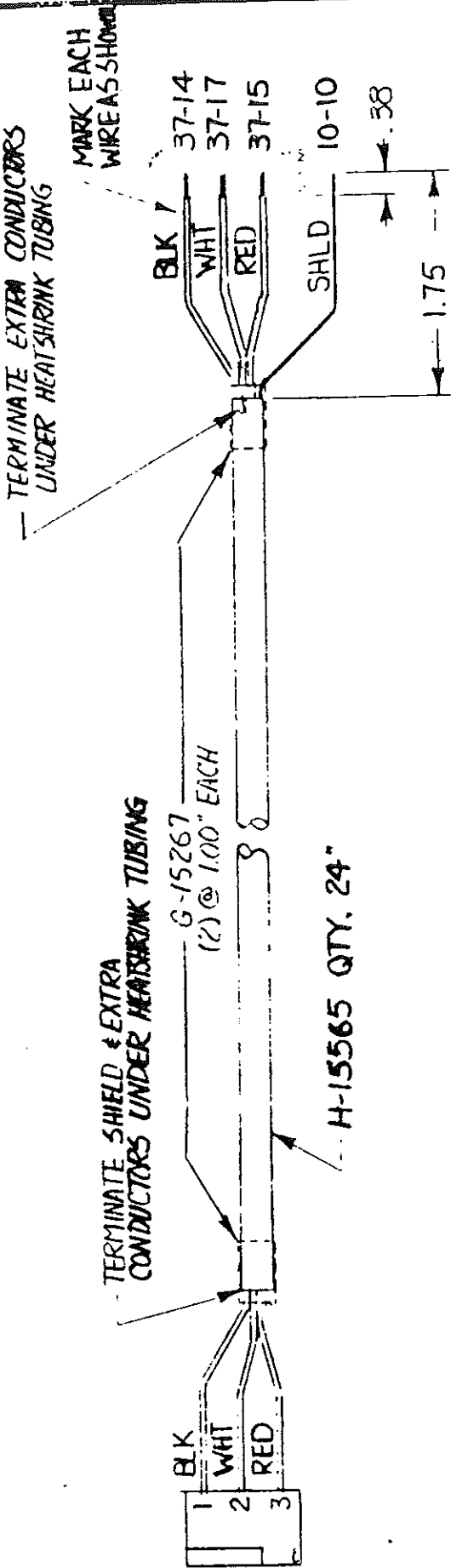

A-79224-003 (1)
A-79225 (3)

NOTES:

1. MARK CABLE WITH DRAWING & CURRENT ISSUE NUMBER.



INDUSTRIAL DEVICES
Radford, Virginia
A HOLLANDER DIVISION

CABLE ASSY RDP BDS4

185	ECN NO.	DATE	REV	REV NO	DATE	APPD	OWN BY	DATE
							EMR	3-5-82
							CHK BY	
							APP'D BY	3/6/92

UNLESS OTHERWISE SPECIFIED
XX DEC PLACES 2,015
XXX DEC PLACES 2,005
ANG DIM 1.1"

DO NOT SCALE DWG. USE DIMENSIONS ONLY
DIMENSIONS ARE IN INCHES
UNLESS OTHERWISE SPECIFIED

SCALE:

DWG. NO. A-93461

DWG. NO. **A-93462** 1

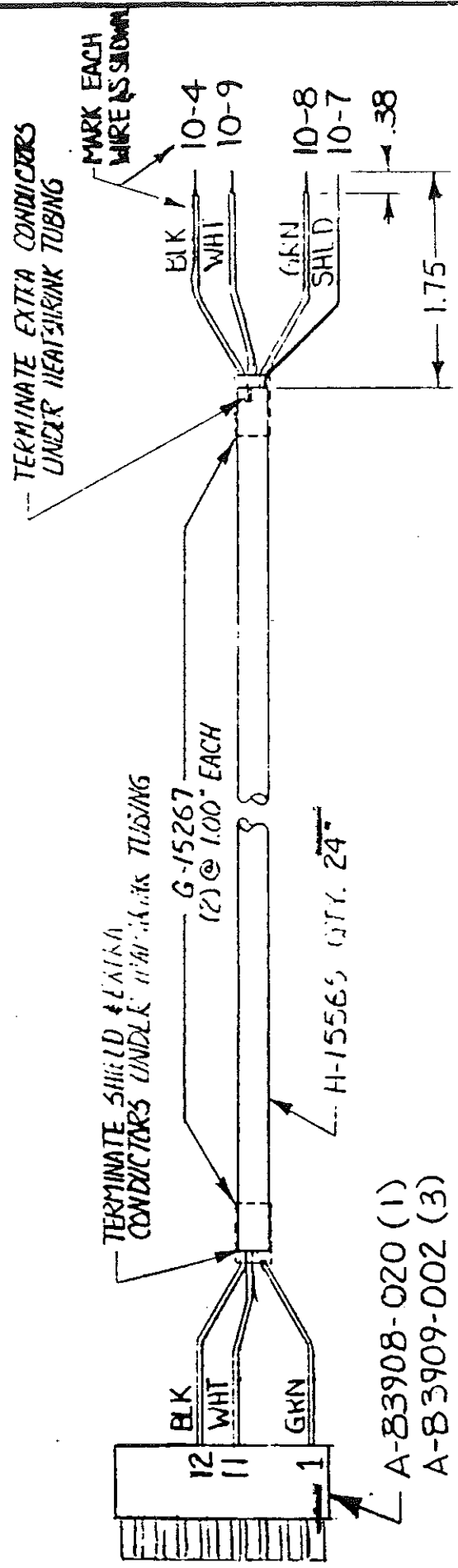

- ∠ A-83908-020 (1)
- ∠ A-83909-002 (3)

NOTES:
 1. MARK CABLE WITH DRAWING & CURRENT ISSUE NUMBER.



INDUSTRIAL DYNAMICS
 Raleigh, Virginia
 A HOLLAND-HEMLOCK COMPANY

UNLESS OTHERWISE SPECIFIED XX DEC. PLACES 2.918 XXX DEC. PLACES 1.998 ANG. DIM. 2.1"		ISS	ECN NO.	DATE	APP'D	ISS	ECN NO.	DATE	APP'D	ECN NO.	DATE	APP'D	OWN BY	DATE
													EWK	3-6-92
													CHM BY	
													APP'D BY	
													SCM	3-16-78
CABLE ASSY - ADP BDS-4													SCALE:	DWG NO.
														A-93462
														1

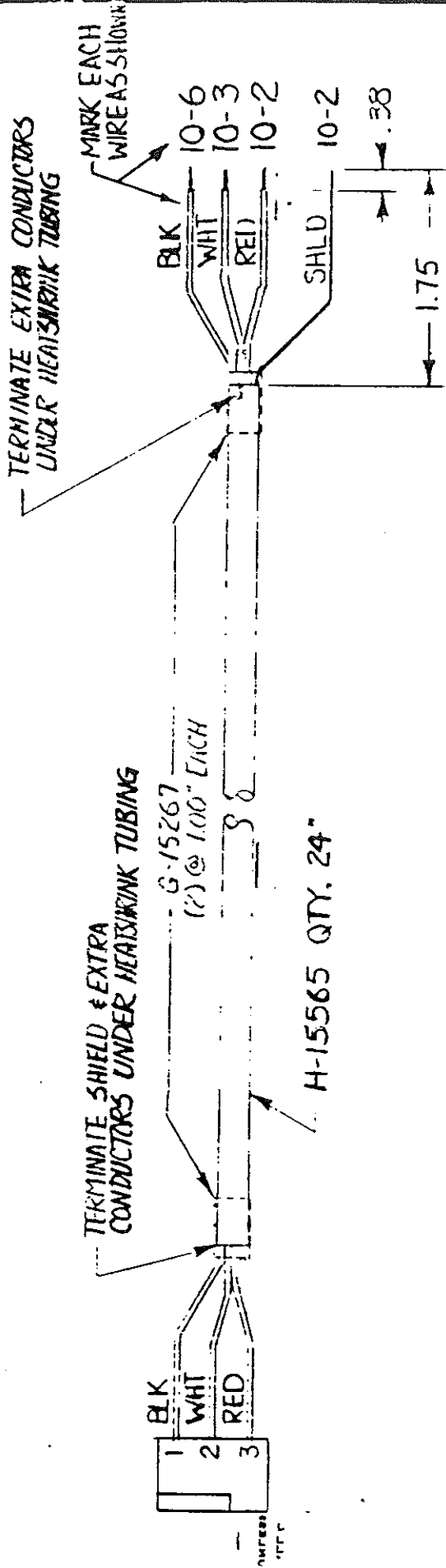

A-79224-003 (1)
A-79225 (3)

NOTES:

1 - MARK CABLE WITH DRAWING & CURRENT ISSUE NUMBER.



INDUSTRIAL DYNAMICS
Radford, VA, U.S.A.
A HOLLAND-AMERICAN DIVISION

CABLE ASSY RDP BD54

UNLESS OTHERWISE SPECIFIED XX DEC. PLACES .015 XXX DEC. PLACES .005 ANG DIM .1"	ISS	ECN NO.	DATE	SYNO	DATE	APPD	DWN BY EWR	DATE
			3-5-92				CHK BY	
DO NOT SCALE DWG. USE DIMENSIONS ONLY ALL DIMENSIONS ARE INCHES UNLESS OTHERWISE SPECIFIED							APP'D BY SCM	3-16-92

SCALE:

DWG NO
A-93463

1

NOTES:

- 1) CONNECTOR KIT "3BC-RDP" IS REQUIRED FOR HOOK-UP OF THIS SYSTEM. SOME EXTRA ITEMS ARE INCLUDED WITH THE KIT, WHICH HAS CONNECTORS FOR 38D29 & 38D42. THESE EXTRA CONNECTORS & PINS MAY BE DISCARDED.
- 2) NO CONNECTION ON 38D-RDP1-101.
- 3) NO CONNECTION ON RDP2-101.

SBD #1

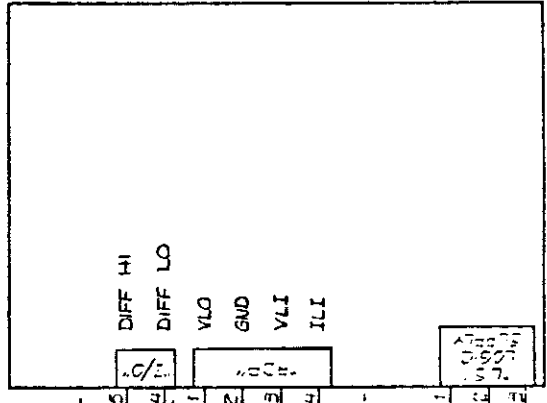
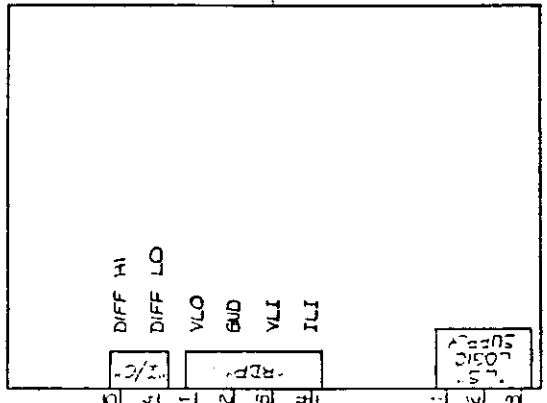

RDP2

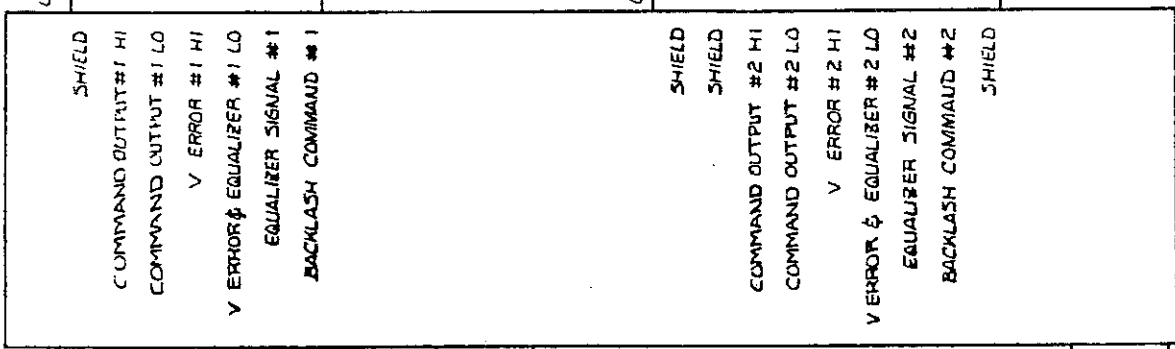

SBD #2

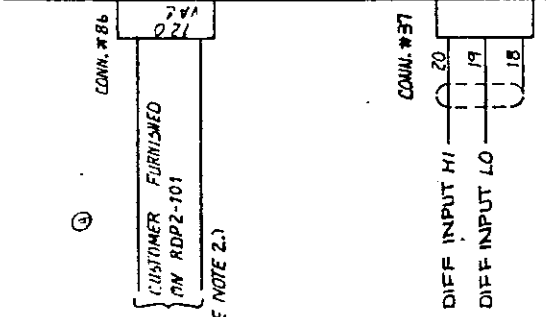

★ THIS CABLE ASS'Y MAY BE OBTAINED FROM INDUSTRIAL DRIVES

5	82874	DIFF HI	25
4	82813	V A	25
3	82566	GND	25
2	81937	TDA	25
REV. EQU NUMBER INITIAL DATE APP'D			



INDUSTRIAL DRIVES	
SOLUTIONS CORPORATION	
2001 W. 10th St. Lincoln, NE 68502	
TYPE	38D-3
DATE	8-11-82
REV.	5

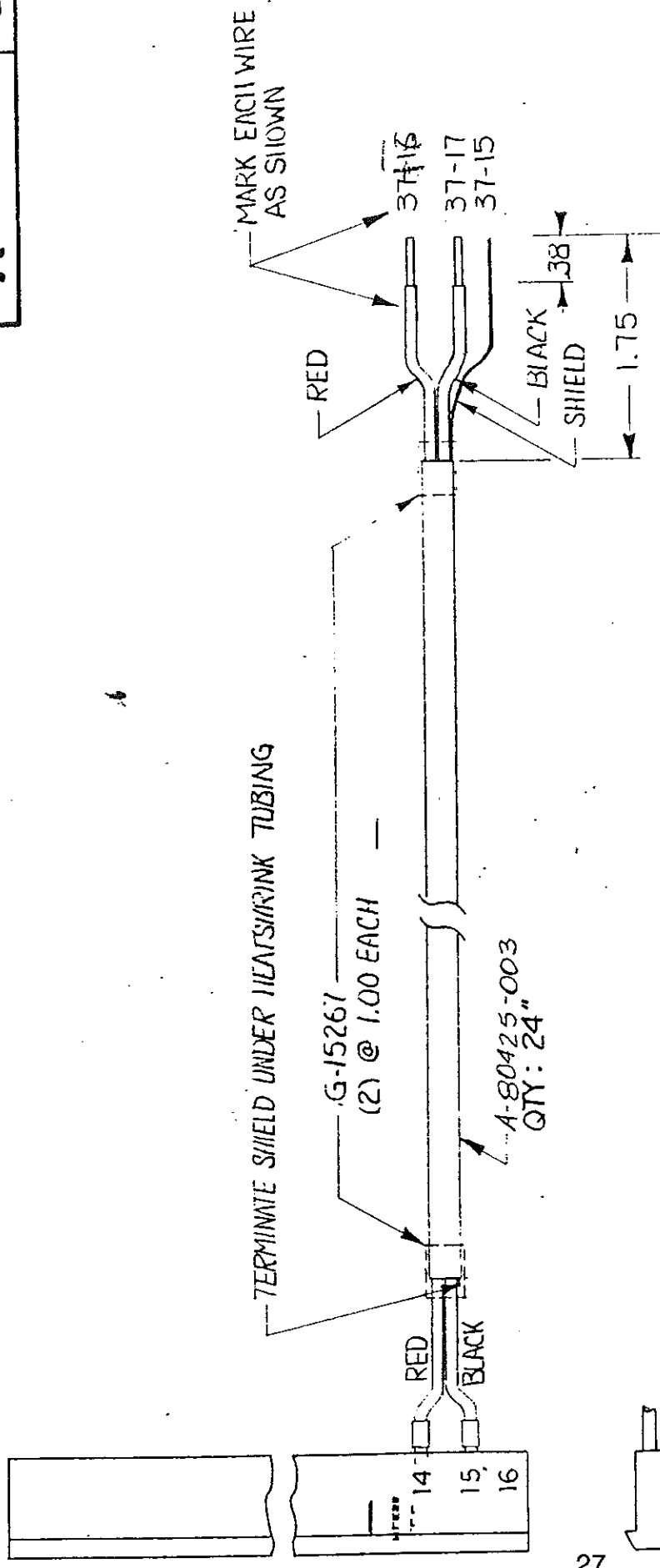

MARK EACH WIRE AS SHOWN

TERMINATE SHIELD UNDER HEATSHRINK TUBING

G-15267
(2) @ 1.00 EACH

A-80425-003
QTY: 24"

RED
BLACK

37-16
37-17
37-15

BLACK SHIELD
1.75
.38

27

A-81584-016 QTY: 1
A-81585 QTY: 2

NOTES:

1- MARK CABLE WITH DRAWING # CURRENT ISSUE NUMBER.



INDUSTRIAL DRIVES
Radford, Virginia
A KOLLMOGER DIVISION

UNLESS OTHERWISE SPECIFIED XX DEC PLACES .010 XXX DEC. PLACES .005 ANG. DIM. ± .1"		ISS.	ECN NO.	DATE	APP'D	ISS.	ECN NO.	DATE	APP'D	DW'N BY	DATE
						2	83890 VA	2-27 91		ENR	3-25-88
										CHK BY	
										APP'D BY	4/7/88
										SCM	
DO NOT SCALE DWG. USE DIMENSIONS ONLY ALL DIMENSIONS ARE INCHES UNLESS OTHERWISE SPECIFIED										SCALE:	ISSUE
										NONE	2
										DWG. NO	
										A-83245	
										CABLE ASSY RDP	

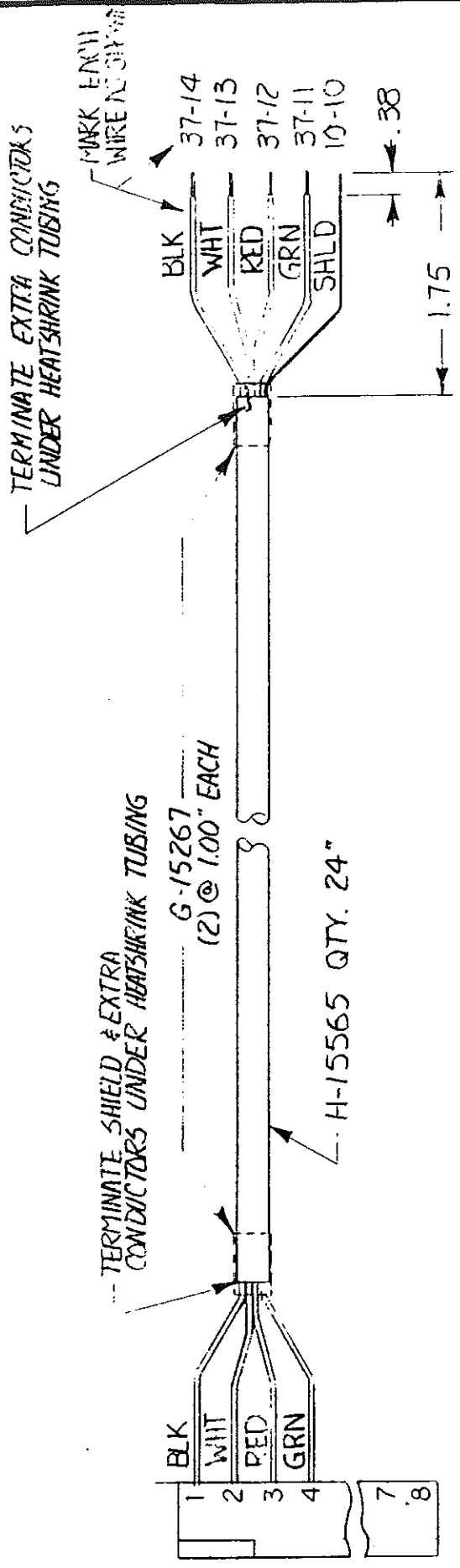

28

- A-79224-008 (1)
- A-79225 (4)

NOTES:

1. MARK CABLE WITH DRAWING & CURRENT ISSUE NUMBER.



INDUSTRIAL DRIVES
Radford, Virginia
A KOLLERBROSCH DIVISION

CABLE ASSY - RDP

SCALE: **A-83246** ISSUE **1**

ISS.	ECN NO.	DATE	APPD	ISS.	ECN NO.	DATE	APPD	DATE	DWN BY	DATE	APPD BY	
											CHK BY	DATE
									EWB	3-25-88		
												4-7-88

UNLESS OTHERWISE SPECIFIED
XX DEC. PLACES ±.015
XXX DEC. PLACES ±.005
ANG. DIM. ±.1°

DO NOT SCALE DWG. USE DIMENSIONS ONLY
ALL DIMENSIONS ARE INCHES
UNLESS OTHERWISE SPECIFIED

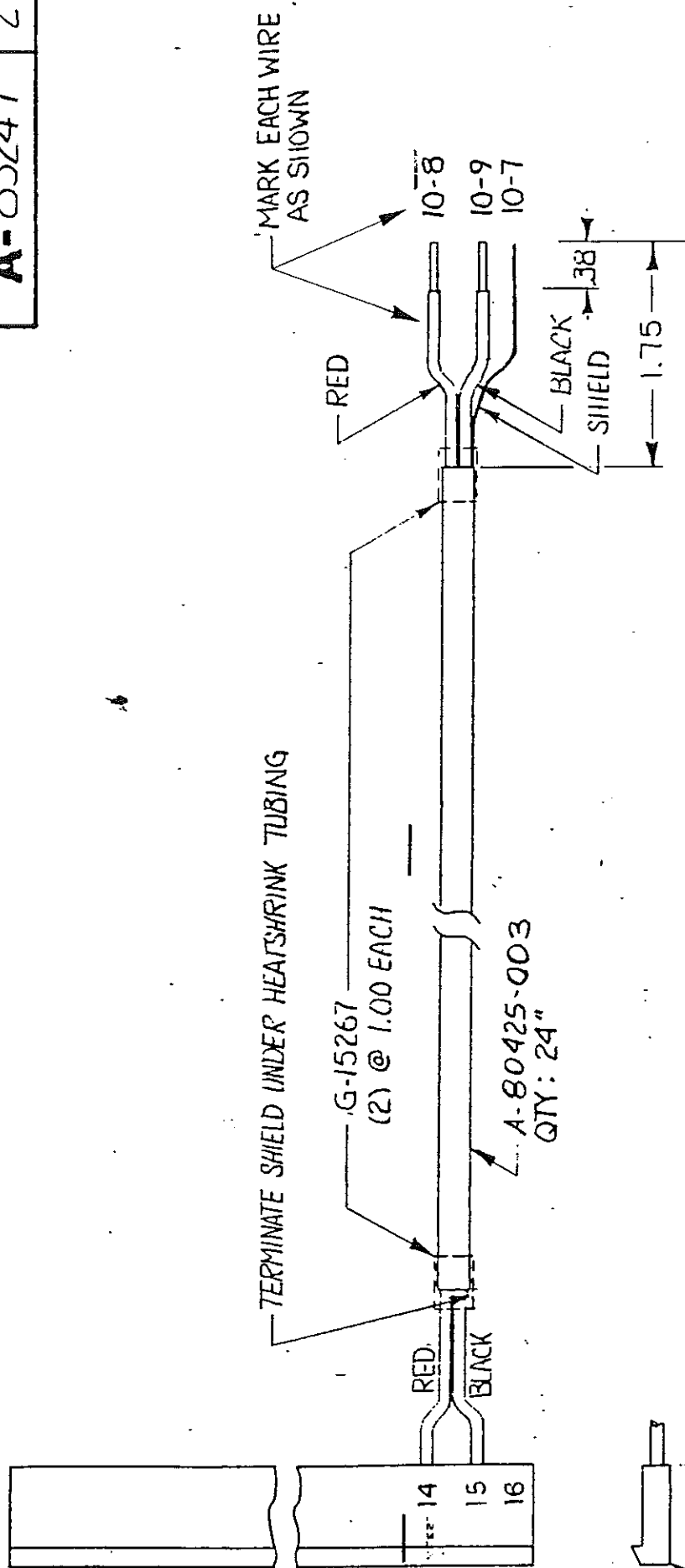

29

A-81584-016 QTY: 1
 A-81585 QTY: 2

NOTES:

1. MARK CABLE WITH DRAWING & CURRENT ISSUE NUMBER.



INDUSTRIAL DRIVES
 Radford, Virginia
 A HOLLANDER DIVISION

UNLESS OTHERWISE SPECIFIED XX DEC PLACES 2, 011 XXX DEC PLACES 2, 001 ANG. DIM. 2, 1"		ISS.	ECN NO.	DATE	APP'D	ISS.	ECN NO.	DATE	APP'D	DATE	OWN BY	DATE
						2	83890 V.A.	2-27 91	Scm		EMR	3-25-88
											CHK BY	
											APP'D BY	4-7-88
											SCALE	NONE
											DWG. NO.	A-83247
											ISSUE	2

CABLE ASSY RDP

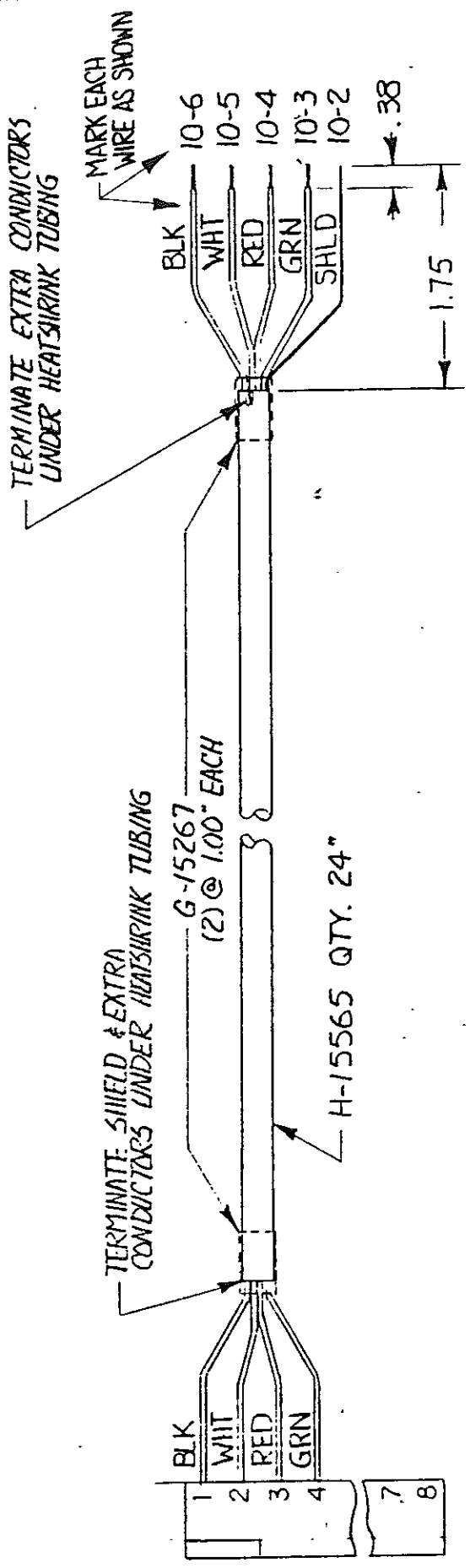

30

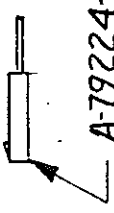

A-79224-008 (1)
A-79225 (4)

NOTES:

1. MARK CABLE WITH DRAWING & CURRENT ISSUE NUMBER.

<p>INDUSTRIAL DRIVES Radford, Virginia A HOLLANDSBACH DIVISION</p>		CABLE ASSY RDP		SCALE:	DWG. NO. A-83248	ISSUE 1
		DATE 3-25-88	DW'N BY EMW	DATE	APPD	ECN NO.
	CHK' BY					
	APPD BY SCM	DATE	DATE	DATE	DATE	DATE
UNLESS OTHERWISE SPECIFIED XX DEC. PLACES .015 XXX DEC. PLACES .005 ANG. DIM. ± .1"						
DO NOT SCALE DWG. USE DIMENSIONS ONLY ALL DIMENSIONS ARE INCHES UNLESS OTHERWISE SPECIFIED						

