

**L Band Wide Receiver Block Diagram**  
March 2003

**NAIC Arecibo Observatory**

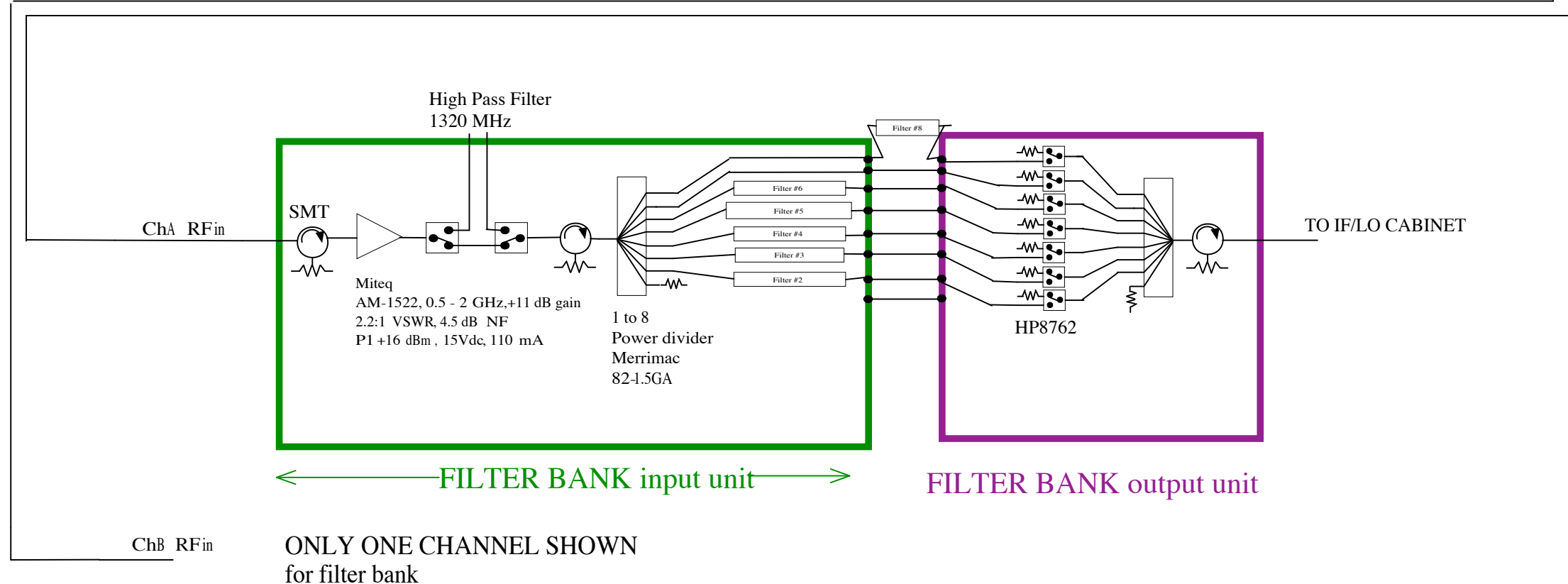

**Filter Bank Addresses and Frequencies**

Filter	Freq (MHz)	Address (ChA/B)
external high pass	1320	500 / 203
2	1120 - 1220	501/204
3	1240 - 1460	502/205
4	1555 - 1730	503/206
5	1130 - 1730	504/207
6	1360 - 1475	505/208
7	none	
8	1180 - 1280	507/210
"9" ext output		508/211