

National Astronomy and Ionosphere Center

**Arecibo Observatory**

**Focal Array Memo Series**

**Final Feed Selection Study  
For the  
Multi Beam Array System**

By: Germán Cortés-Medellín

**CORNELL**  
University

July/19/2002  
Rev. 00



National Science  
Foundation

## INDEX

1.	Introduction.....	3
2.	Antenna Analysis Methodology .....	3
2.1	Frequency Band .....	3
2.2	Polarization .....	3
2.3	Radiation Patterns .....	3
2.4	Edge Taper Angle .....	3
2.5	Antenna Gain and G/T Analysis .....	3
3.	Feed Horn Characteristics.....	3
3.1	CSIRO Coaxial Horn, 22cm Aperture .....	3
3.2	CSIRO TE <sub>11</sub> Mode Horn, 25cm Aperture.....	4
4.	Feed Horn Performance .....	4
4.1	Feed Horn Radiation Patterns .....	4
4.2	Feed Horn 60°Spillover Efficiency.....	4
5.	Optics and Array Layout.....	5
6.	Multi Beam Antenna Performance .....	6
6.1	Feed Horn: CSIRO Coaxial 19.6 cm x 20.4 cm .....	7
6.2	Feed Horn: CSIRO Coaxial 22.0 cm x 22.8 cm .....	9
6.3	Feed Horn: Parkes TE <sub>11</sub> mode Horn 24 cm x 26.25 cm .....	11
6.4	Feed Horn: CSIRO TE <sub>11</sub> mode Horn 25 cm x 26.0 cm.....	13
6.5	Feed Horn: NIAC TE <sub>11</sub> mode Horn 26 cm x 26.8 cm .....	15
7.	Comparative Antenna Sensitivity and $A_{\text{eff}}/T_{\text{sys}}$ .....	16
8.	Sky Footprint and Multi-Beam Characteristics .....	18
8.1	Feed Motion vs. Antenna Far Field Beam Motion .....	18
8.2	Antenna Far Field Multi Beam Characteristics .....	18
8.3	Multi Beam Comatic Levels .....	21
8.4	Total Multi Beam Incoherent Pattern .....	22
8.5	Drift Scan Sampling and Multi Beam.....	22
9.	Conclusions.....	26
	Appendix A.....	27

## 1. Introduction

This document presents the evaluation of the two CSIRO feed designs for the Arecibo Multi-Beam Array System, namely, a 22cm aperture coaxial horn and a  $TE_{11}$  mode feed horn, with 25cm aperture diameter. We made a comparison of the feed performance of these two designs in the multi beam system with the performance of previously analyzed feed horns<sup>1</sup>.

In addition, a comparison in terms of the imaging characteristics, sky footprint, coma levels, beam-overlapping levels, and drifts scan characteristics for these two feeds is also included.

## 2. Antenna Analysis Methodology

### 2.1 Frequency Band

For each horn we analyzed three frequency points in the L-Band:

- 1.225 GHz
- 1.375 GHz
- 1.525 GHz

### 2.2 Polarization

The horns were linearly polarized (VERT or HORZ).

### 2.3 Radiation Patterns

Dr. Bird provided radiation patterns at the three specified frequencies in the form of E and H plane cuts with  $\theta < 180$  deg; with both magnitude and phase for each cut.

### 2.4 Edge Taper Angle

The tertiary reflector edge of the Arecibo Gregorian System is at an angle of  $60^\circ$  with respect the optical axis of the feeds.

### 2.5 Antenna Gain and G/T Analysis

We obtained a spherical wave expansion of the feed radiation patterns, and we proceeded to perform a complete antenna gain analysis of the Arecibo radio telescope optics by a combination of kinematics and electrodynamic ray tracing, and aperture field integration. Finally, we performed a noise analysis as seen by the feed to obtain the overall G/T, using all previous techniques in conjunction with a detailed Gregorian noise mapping.

## 3. Feed Horn Characteristics

### 3.1 CSIRO Coaxial Horn, 22cm Aperture

This feed horn is similar to Lowell's coaxial horn, with a diameter of 22.0 cm, a 4.0 cm inner conductor. The horns have a return loss  $> 22$  dB across the band. The radiation patterns were obtained with the horn located on a 100 cm diameter ground plane.

---

<sup>1</sup> Germán Cortés-Medellín, "Feed Selection", *Arecibo Observatory Focal Array Memo Series*, National Astronomy and Ionosphere Center, Cornell University, July 29, 2001.

### 3.2 CSIRO TE<sub>11</sub> Mode Horn, 25cm Aperture

This feed horn design is a stepped TE<sub>11</sub> mode horn similar to Parkes, with an aperture diameter of 25.0 cm, and approximately 60 cm in length. The horn design uses four steps and have a return loss > 22 dB across the band. The radiation patterns were obtained with the horn aperture located on an 80 cm diameter ground plane.

## 4. Feed Horn Performance

### 4.1 Feed Horn Radiation Patterns

The radiation patterns of these two designs are presented in the Appendix A, along with the radiation patterns of the last 3 feed horns previously analyzed<sup>1</sup>, namely, Dr. Bird's 19.6 coaxial feed horn, Parkes 24.0 cm TE<sub>11</sub> mode Horn, and our 26.0 cm TE<sub>11</sub> mode horn.

### 4.2 Feed Horn 60° Spillover Efficiency

Figure 4.1 shows the calculated feed horn 60° spillover efficiency. CSIRO TE<sub>11</sub> mode horn 25 cm design has the highest overall spillover efficiency, followed by the 26 cm TE<sub>11</sub> mode horn design. Only at the upper end of the band CSIRO Coaxial 22.0 cm design produces a higher value of spillover efficiency. Hence, CSIRO TE<sub>11</sub> mode horn 25 cm design it is expected to have a lower noise antenna temperature than CSIRO Coaxial 22.0 cm design all over the band except possibly at the highest end.

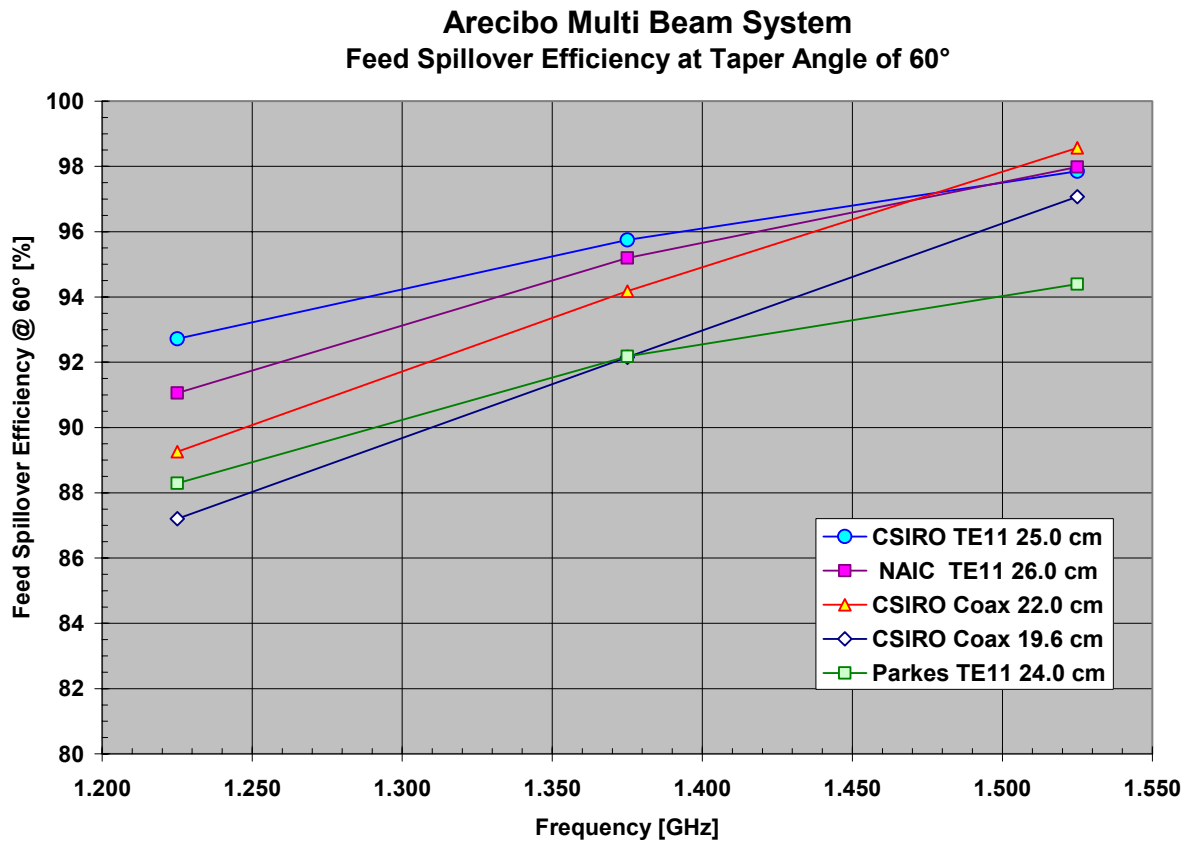


Figure 4.1 Feed 60° Spillover Efficiency

## 5. Optics and Array Layout

Figure 5.1 shows the array layout convention in the focal plane and the orientation of the focal plane in the antenna in Figure 5.2

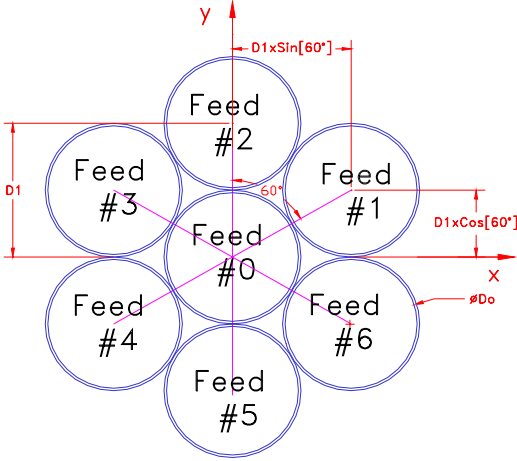


Figure 5.1 Array Layout in the Focal Plane

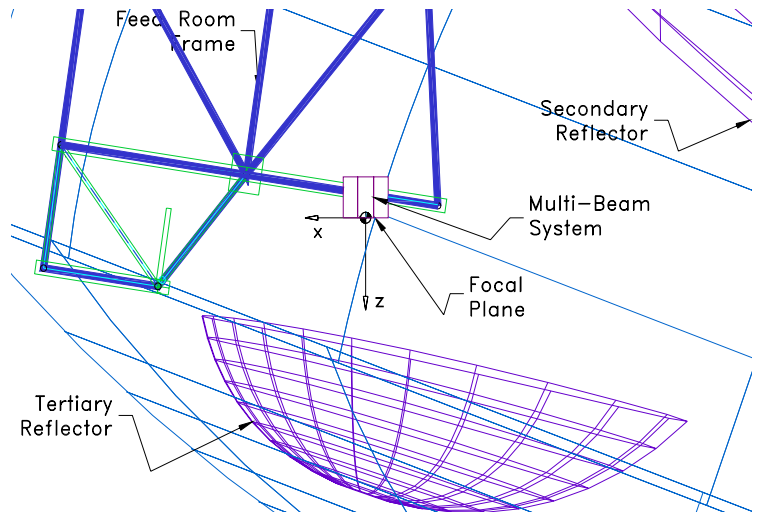


Figure 5.2 Coordinate system in the Focal Plane

Figure 5.3 shows the scanning loss of the Arecibo Gregorian System in the focal plane along the x and y axis at 1.375 GHz. The system is symmetrical along the y-axis from  $y < 0$  to  $y > 0$ , but is asymmetrical along the x-axis, with a higher level of scanning loss along  $x < 0$ .

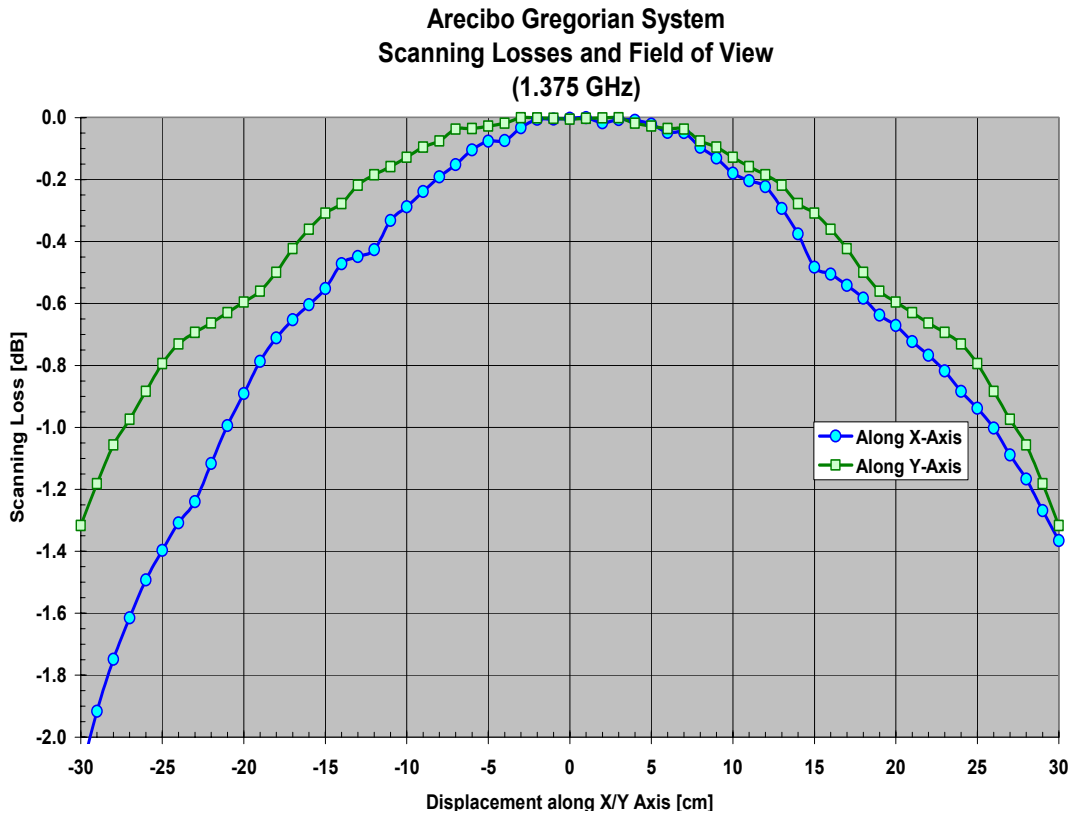


Figure 5.3 Scanning Losses in the FOV for the Arecibo Gregorian System

In order to compensate for this asymmetry, we shift the center position of the multi beam system by a given amount along the x-axis to equalize the scanning losses for all the exterior pixels.

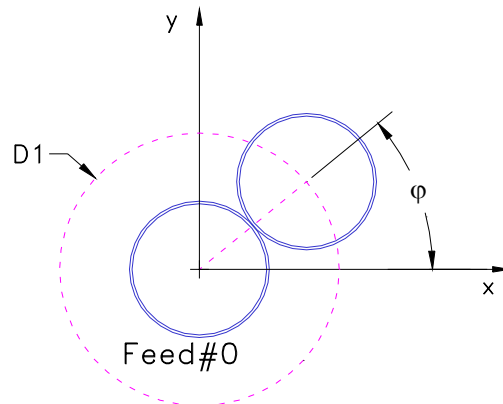
Table 5.1 summarizes the feed characteristics as the feed aperture diameter,  $D_0$ , and center-to-center separation,  $D_1$ , and the X-offset used for all the horns in the calculations.

**Table 5.1 Feed Horn Aperture and Center-to-Center Separation in the Array**

Feed Horn Type	Aperture Diameter [cm]	Center-to-Center Separation [cm]	X-Offset [cm]
CSIRO Coax 19.6	19.60	20.40	1.75
CSIRO Coax 22.0	22.00	22.80	2.40
Parkes TE11 24.0	24.00	26.25	2.80
CSIRO TE11 25.0	25.00	26.00	2.70
NAIC TE11 26.0	26.00	26.80	2.60

## 6. Multi Beam Antenna Performance

We evaluated the antenna performance for five multi beam systems, using each of the horns shown in Table 5.1. In order to further study the astigmatic levels of the Arecibo Gregorian FOV, for the exterior pixels, we calculated the overall antenna performance as a function of angular position, from  $0^\circ$  to  $180^\circ$ , in  $30^\circ$  steps, as indicated in Figure 6.1.



**Figure 6.1 Geometry of external feed location as a function of angle in the Focal Plane.**

We assumed the following gain loss contributions from feeds and the Arecibo Gregorian,

Table 6.1 Antenna Contributions to Gain Losses		
<b>Gain Losses Contributions from Feeds</b>		
Insertion Losses	-0.01	dB
VSWR (Worst Case)	1.300:1	
<b>Gain Losses Contribution from Arecibo Gregorian</b>		
Additional Losses from Physical Optics Cal.	-0.30	dB
Scattering and Blockage	-0.26	dB

The antenna G/T and antenna system temperature assume the temperature conditions shown in Table 6.2.

Table 6.2 System Temperature Contributions		
Scattering	4	K
Physical Temperature	300	K
Receivers Temperature	8	K
Sky Temperature (to be convolved with the antenna pattern)	6	K

Sections 6.1 through 6.5 present the Antenna Sensitivity, Antenna G/T and Antenna System Temperatures for each of the five horns as a function of feed angular position. The performance of Pixel/Horn #0 is also shown in the respective figures superimposed at  $\phi=0^\circ$ .

### 6.1 Feed Horn: CSIRO Coaxial 19.6 cm x 20.4 cm

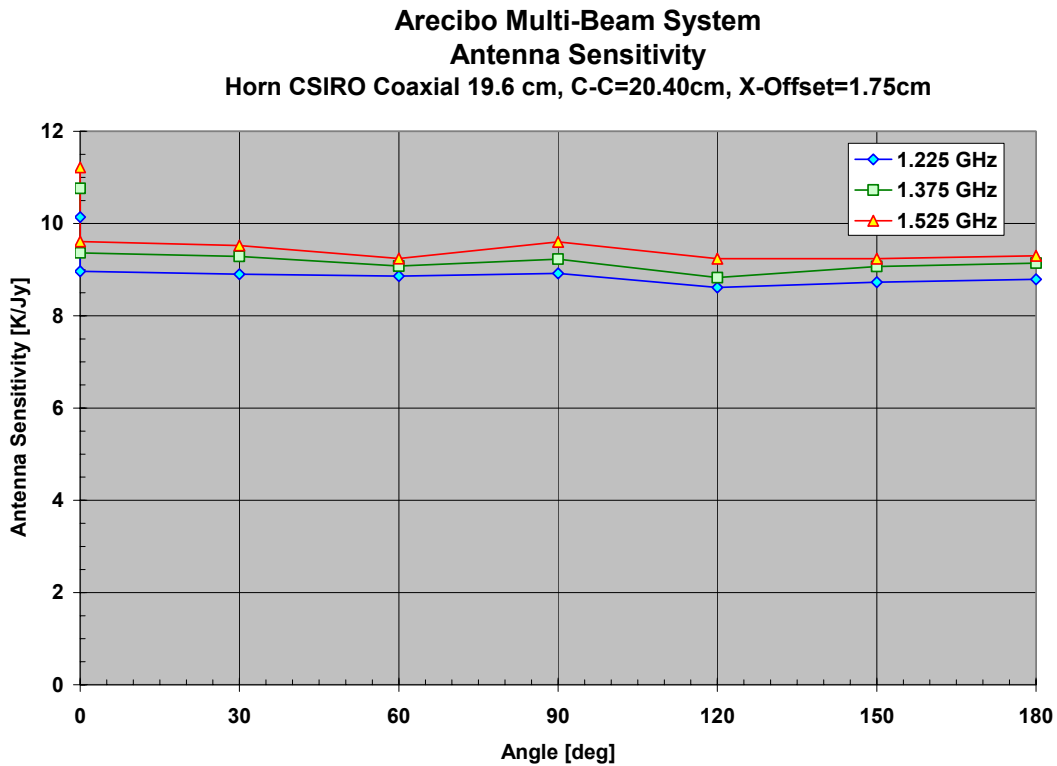
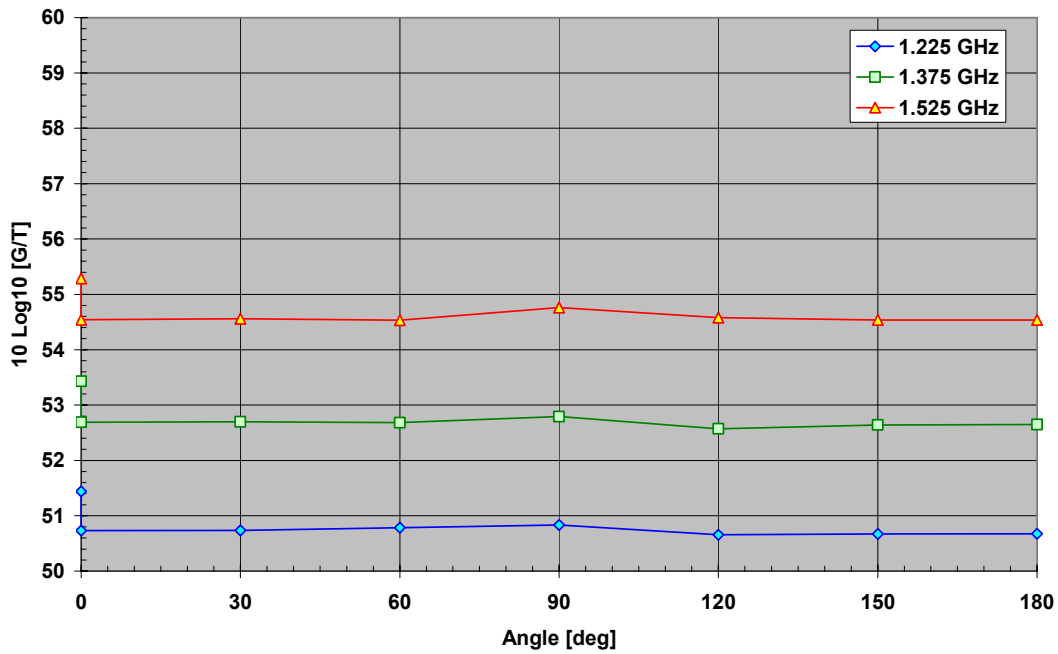


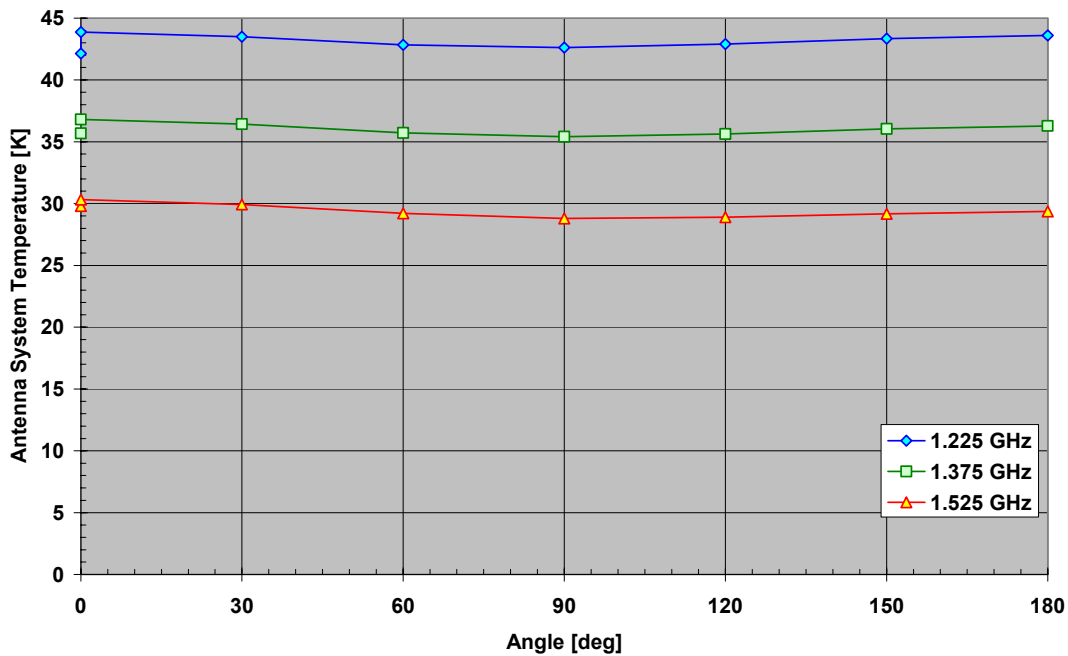
Figure 6.1.1 Antenna Sensitivity as a function of Feed angular position

**Arecibo Multi-Beam System  
Antenna G/T**  
Horn CSIRO Coaxial 19.6 cm, C-C=20.40cm, X-Offset=1.75cm



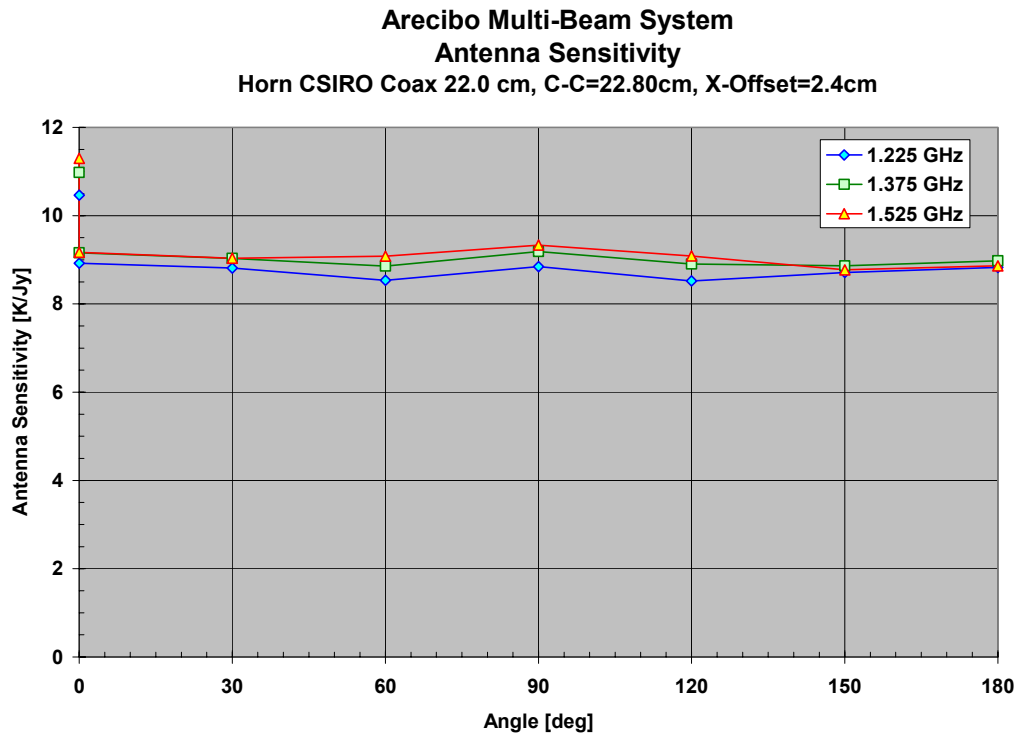
**Figure 6.1.2 Antenna G/T as a function of Feed angular position**

**Arecibo Multi-Beam System  
Antenna System Temperature**  
Horn CSIRO Coaxial 19.6 cm, C-C=20.40cm, X-Offset=1.75cm

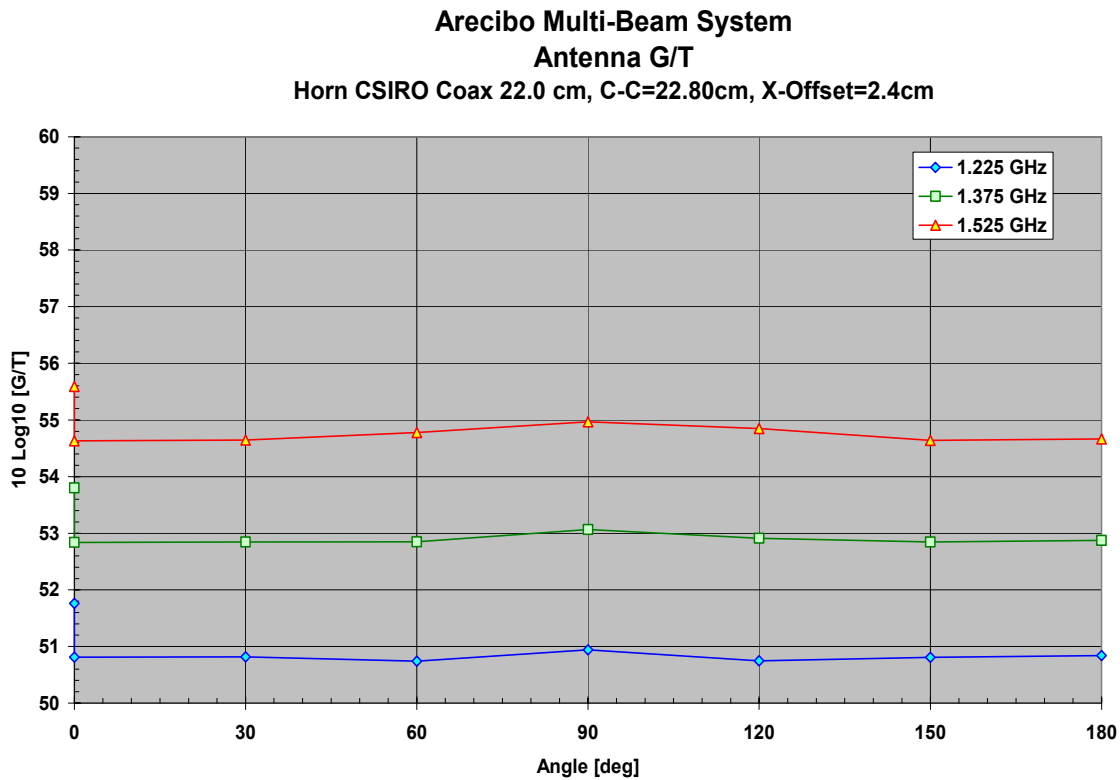


**Figure 6.1.3 Antenna System Temperature as a function of Feed angular position**

## 6.2 Feed Horn: CSIRO Coaxial 22.0 cm x 22.8 cm



**Figure 6.2.1 Antenna Sensitivity as a function of Feed angular position**



**Figure 6.2.2 Antenna G/T as a function of Feed angular position**

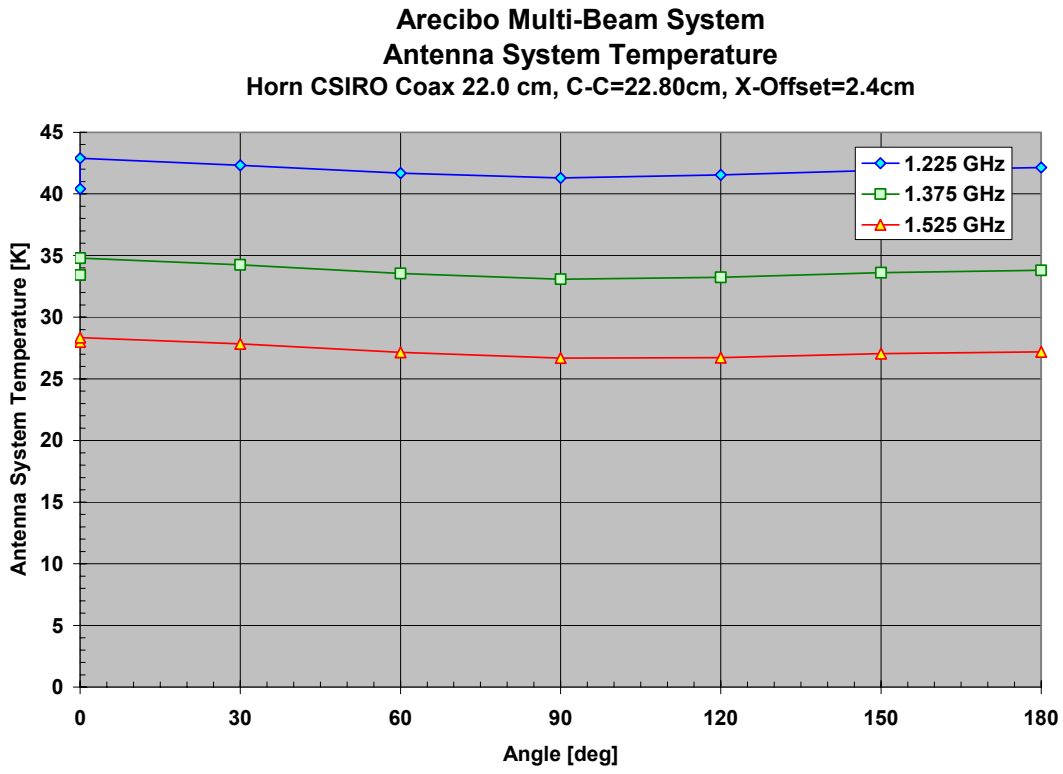


Figure 6.2.3 Antenna System Temperature as a function of Feed angular position

### 6.3 Feed Horn: Parkes TE11 mode Horn 24 cm x 26.25 cm

#### Arecibo Multi-Beam System

#### Antenna Sensitivity

Horn Parkes TE11 24.0 cm, C-C=26.25cm, X-Offset=2.8cm

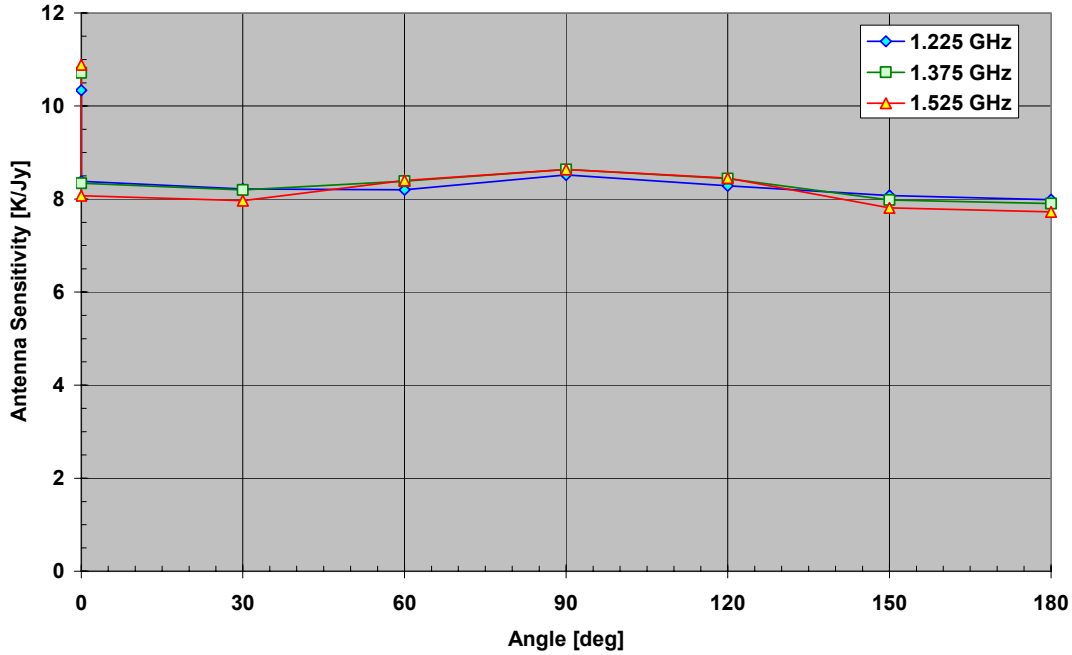


Figure 6.3.1 Antenna Sensitivity as a function of Feed angular position

#### Arecibo Multi-Beam System

#### Antenna G/T

Horn Parkes TE11 24.0 cm, C-C=26.25cm, X-Offset=2.8cm

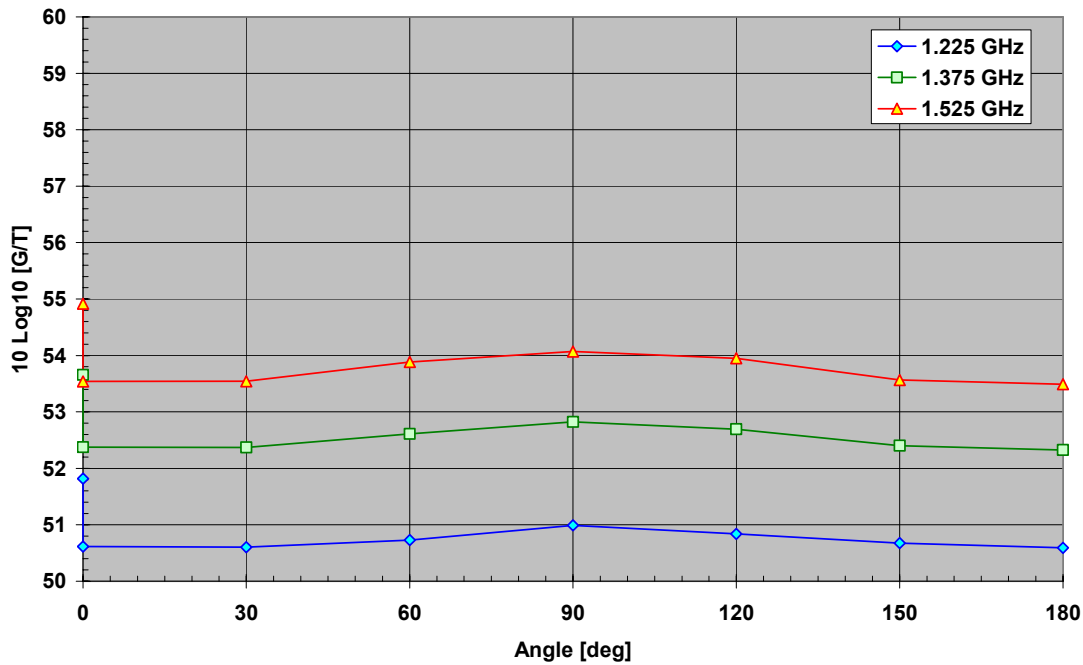
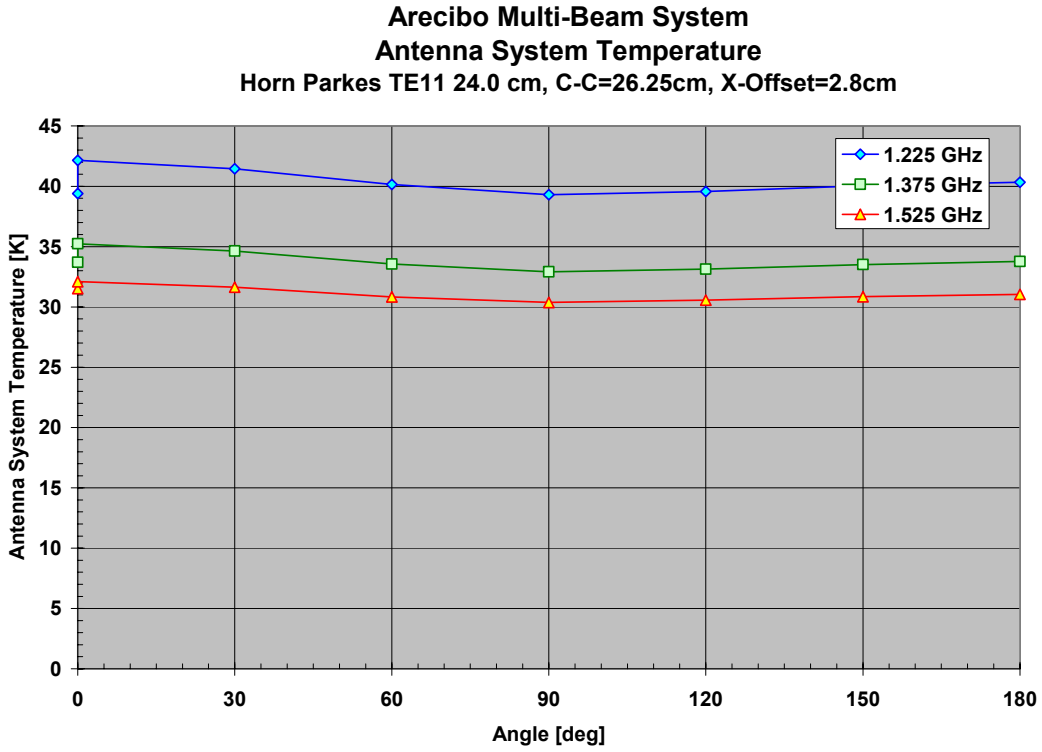


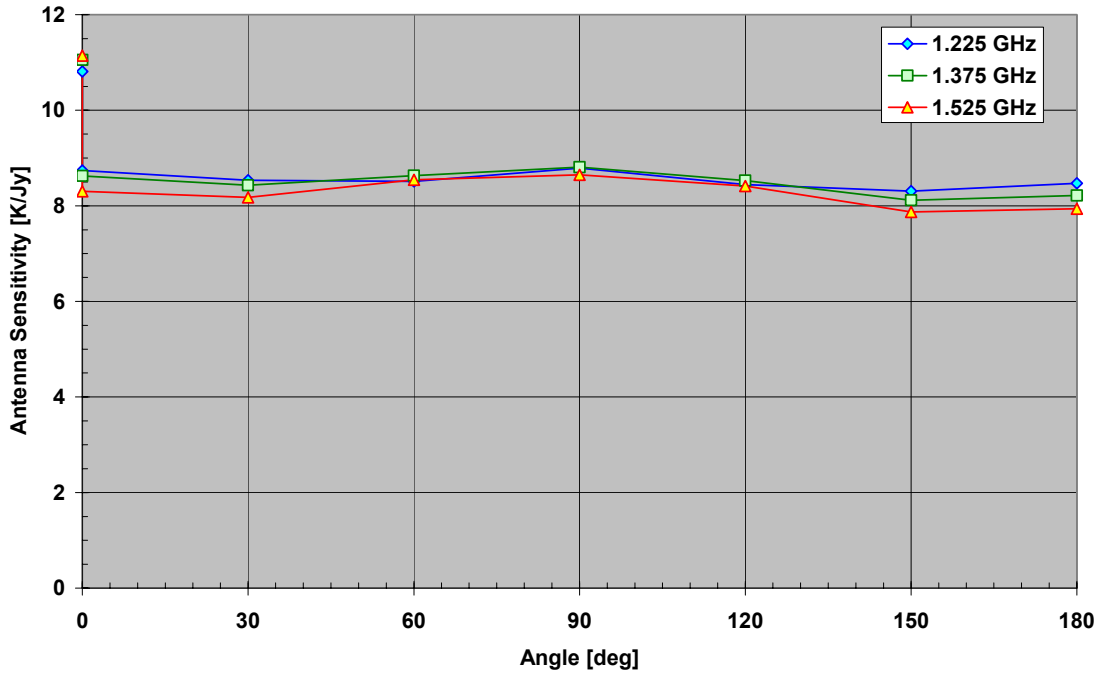
Figure 6.3.2 Antenna G/T as a function of Feed angular position



**Figure 6.3.3 Antenna System Temperature as a function of Feed angular position**

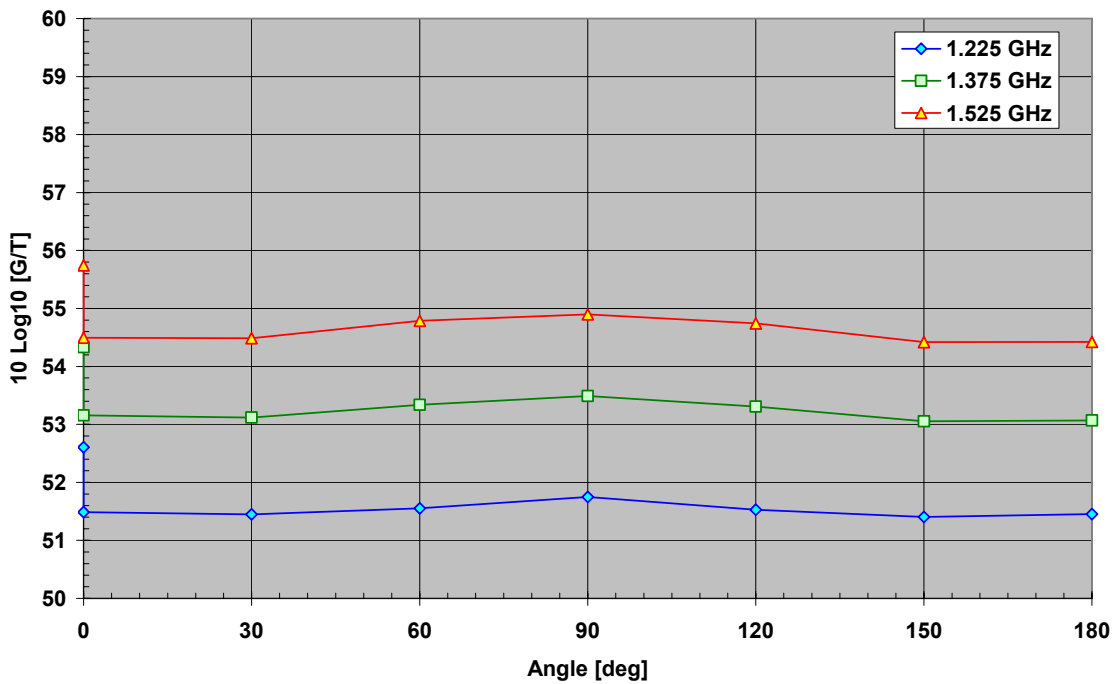
### 6.4 Feed Horn: CSIRO TE11 mode Horn 25 cm x 26.0 cm

**Arecibo Multi-Beam System**  
**Antenna Sensitivity**  
 Horn CSIRO TE11 25.0 cm, C-C=26.00cm, X-Offset=2.7cm



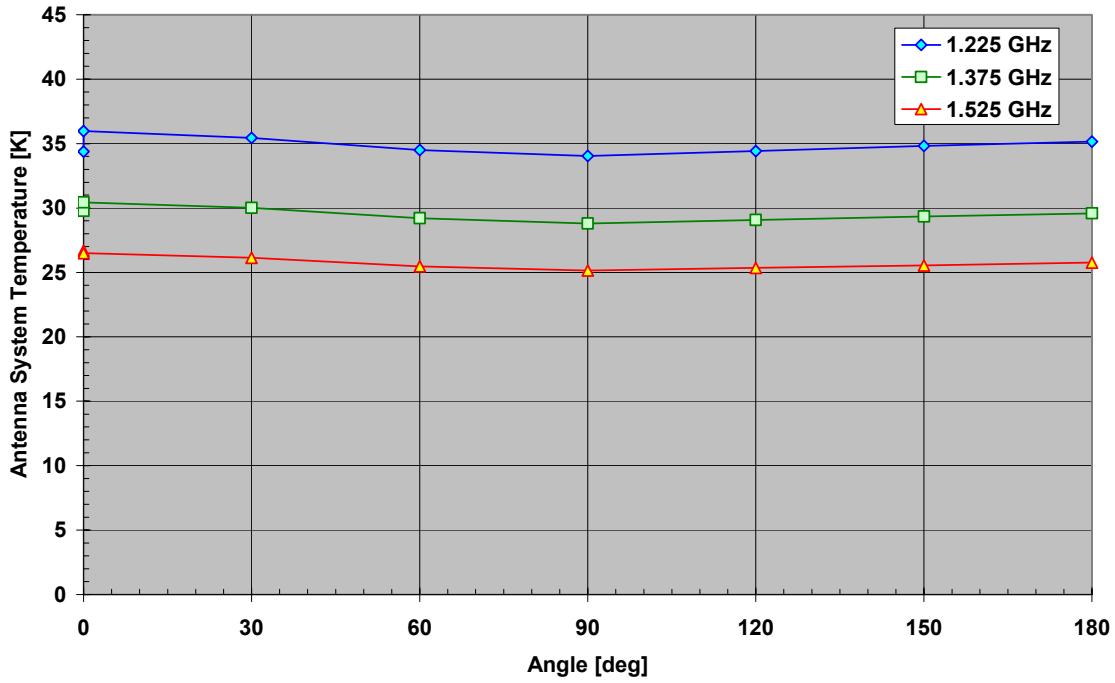
**Figure 6.4.1 Antenna Sensitivity as a function of Feed angular position**

**Arecibo Multi-Beam System**  
**Antenna G/T**  
 Horn CSIRO TE11 25.0 cm, C-C=26.00cm, X-Offset=2.7cm



**Figure 6.4.2 Antenna G/T as a function of Feed angular position**

**Arecibo Multi-Beam System**  
**Antenna System Temperature**  
Horn CSIRO TE11 25.0 cm, C-C=26.00cm, X-Offset=2.7cm



**Figure 6.4.3 Antenna System Temperature as a function of Feed angular position**

### 6.5 Feed Horn: NAIC TE<sub>11</sub> mode Horn 26 cm x 26.8 cm

#### Arecibo Multi-Beam System

#### Antenna Sensitivity

Horn NAIC TE<sub>11</sub> 26.0 cm, C-C=26.8cm, X-Offset=2.6cm

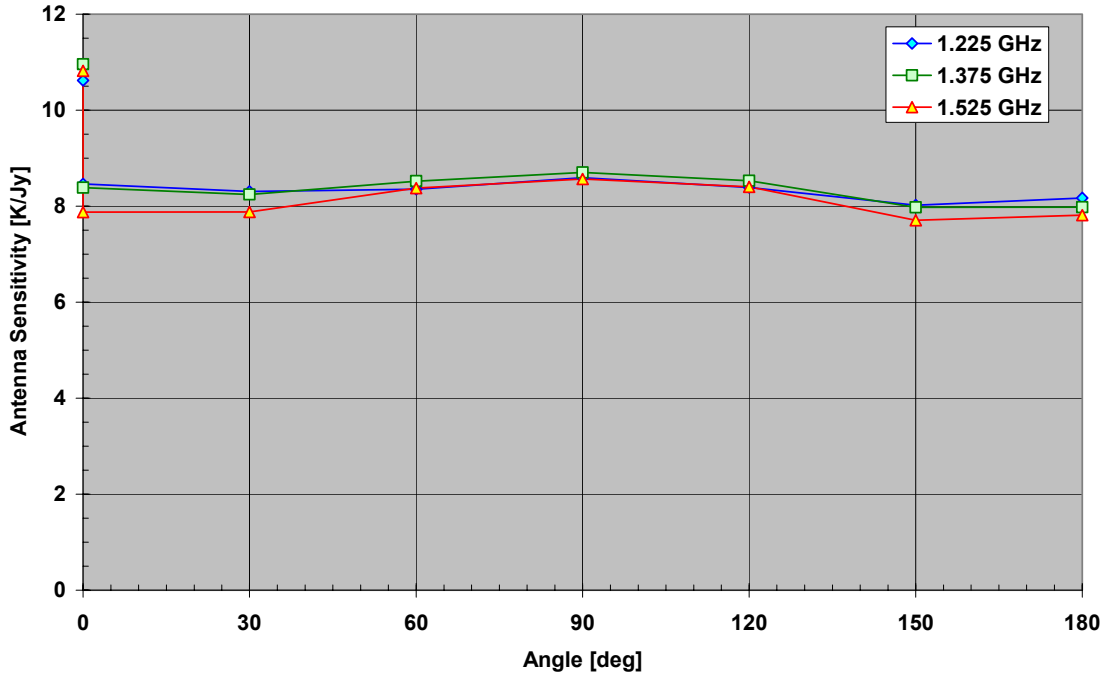


Figure 6.5.1 Antenna Sensitivity as a function of Feed angular position

#### Arecibo Multi-Beam System

#### Antenna G/T

Horn NAIC TE<sub>11</sub> 26.0 cm, C-C=26.8cm, X-Offset=2.6cm

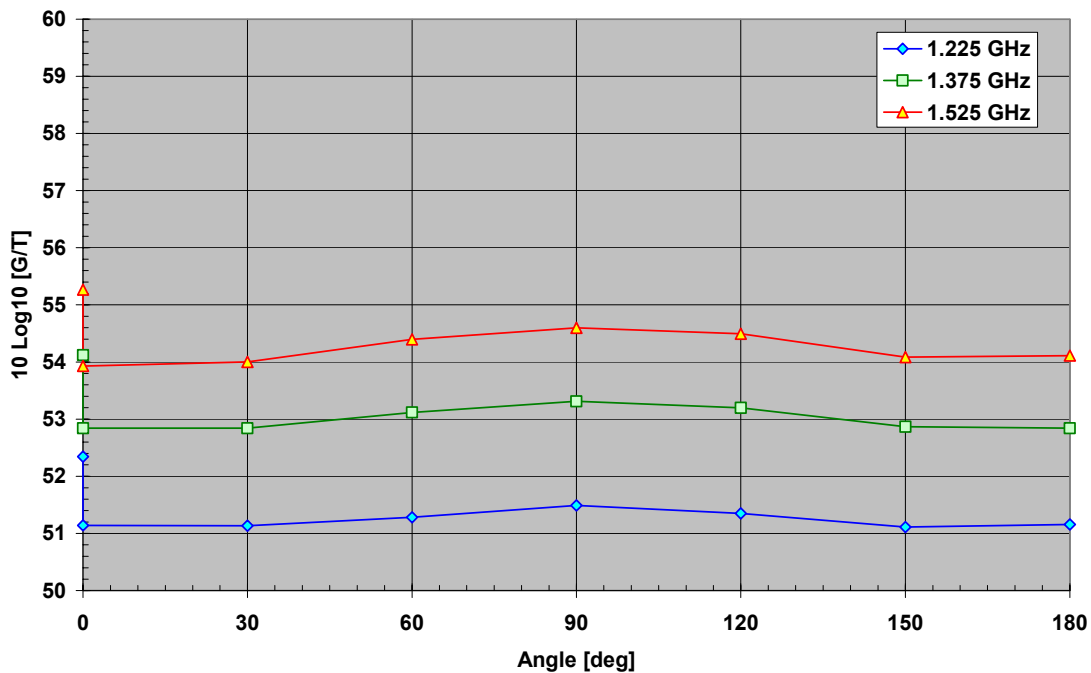


Figure 6.5.2 Antenna G/T as a function of Feed angular position

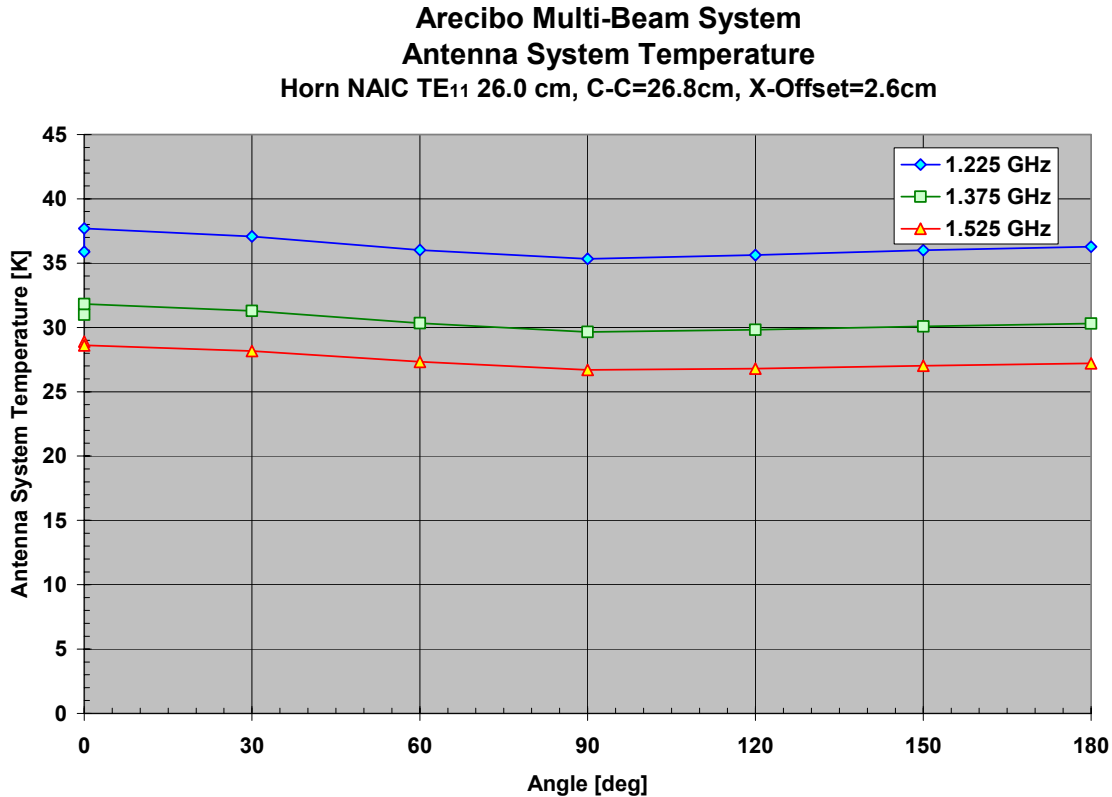


Figure 6.5.3 Antenna System Temperature as a function of Feed angular position

## 7. Comparative Antenna Sensitivity and $A_{\text{eff}}/T_{\text{sys}}$

By averaging the antenna performance in frequency, and for all feeds surrounding the center feed, as a function of azimuth angle  $\phi$  as well, we obtained the antenna sensitivity shown in Figure 7.1. The highest antenna sensitivity is a tie between the center pixel/feed of CSIRO Coax 22.0 x 22.8 cm feed and CSIRO TE<sub>11</sub> mode 25.0 x 26.0 cm feed. While for the surrounding pixels/feeds CSIRO Coax 22.0 x 22.8 cm feed is slightly better.

The antenna  $A_{\text{eff}}/T_{\text{sys}}$ , is shown in Figure 7.2. In particular, for the two candidates we show  $A_{\text{eff}}/T_{\text{sys}}$  with and without a full Noise Tertiary Skirt. In both cases, the multi beam with the highest average  $A_{\text{eff}}/T_{\text{sys}}$ , is CSIRO TE<sub>11</sub> mode 25.0 x 26.0 cm feed. This result is consistent with the feed spillover efficiency shown in Figure 4.1

### Arecibo Multi-Beam System Antenna Sensitivity

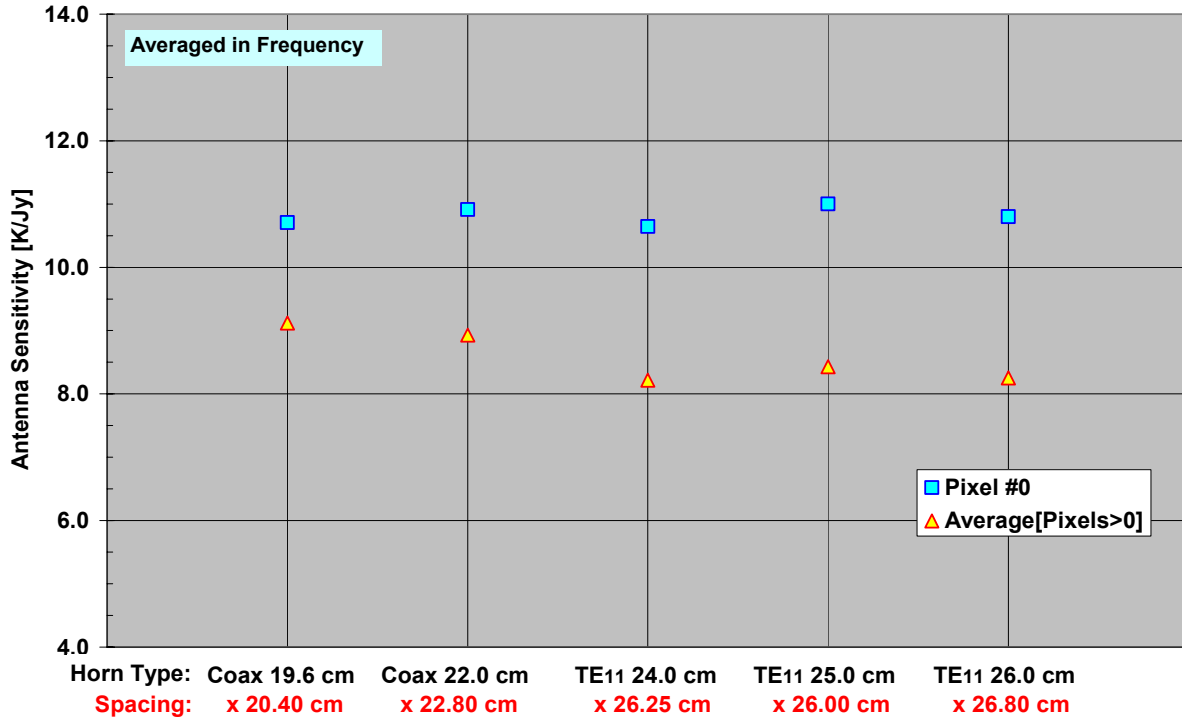


Figure 7.1 Antenna Sensitivity (Aeff in K/Jy) for all feeds (frequency and angle averaged)  
Arecibo Multi-Beam System  
Antenna Aeff/T

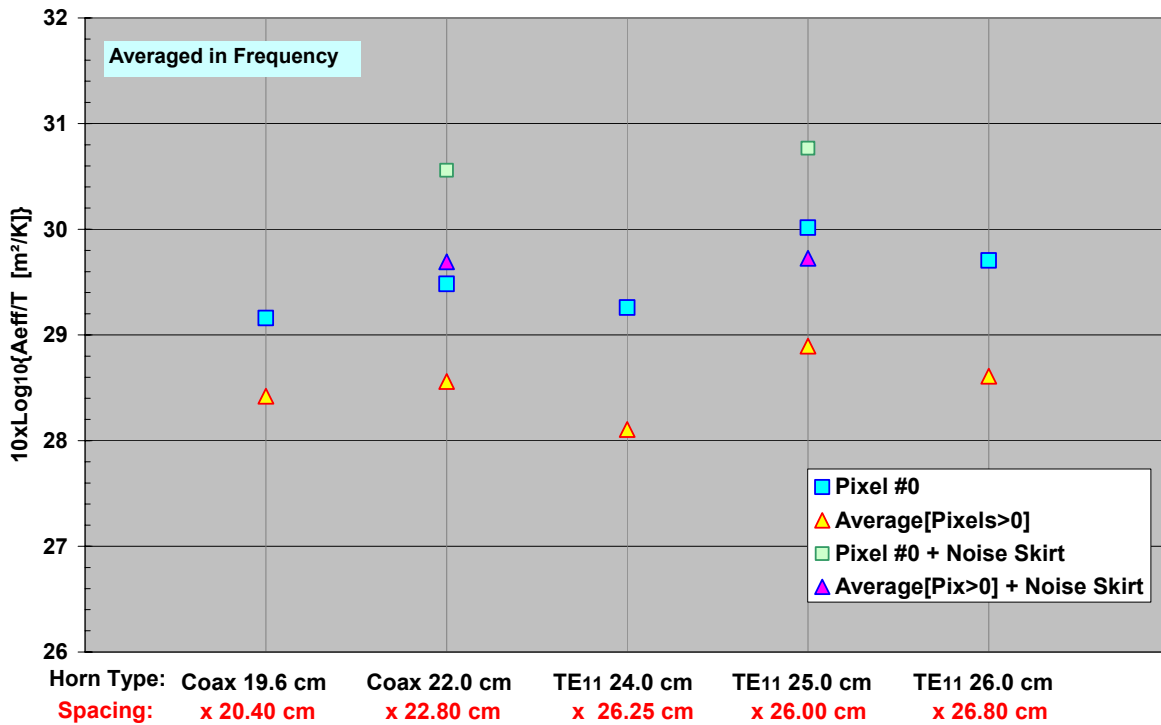


Figure 5.2 Antenna Aeff/T for all feeds (frequency and angle averaged)

## 8. Sky Footprint and Multi-Beam Characteristics

In addition to antenna sensitivity and G/T ( $A_{\text{eff}}/T$ ) the multi beam sky footprint and beam characteristics are also of importance for surveys strategies, sky coverage and sampling. In this section we are presenting the imaging characteristics of the two leading candidate horns for the Arecibo Multi Beam System, namely the Coaxial 22.0x22.8cm horn and the TE<sub>11</sub> mode horn 25x26cm.

### 8.1 Feed Motion vs. Antenna Far Field Beam Motion

When the feed moves in the focal plane as shown in Figure 8.1, the corresponding beam footprint moves in the sky according with Figure 8.2, Our reference axis, the U-axis goes from the zenith to horizon parallel to Arecibo feed arm.

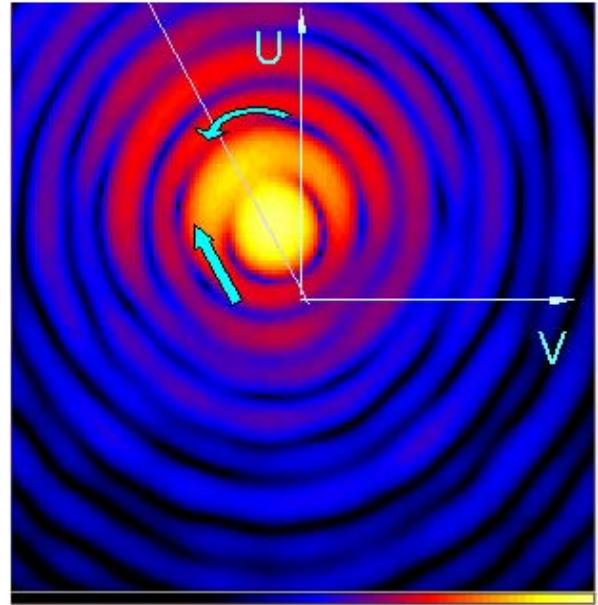
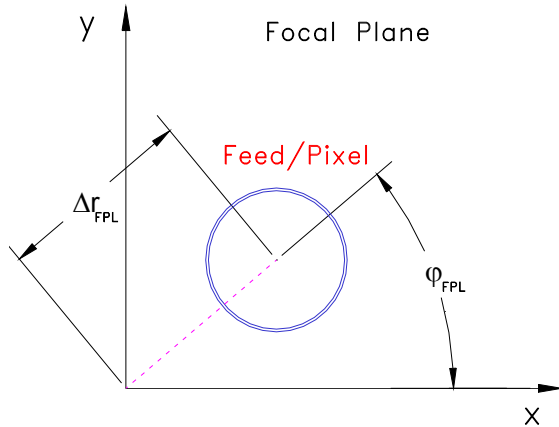


Figure 8.1 Feed motion in the Focal Plane.

Figure 8.2 Beam Motion in the Far Field. (U-axis is parallel to the feed arm)

### 8.2 Antenna Far Field Multi Beam Characteristics

We characterize the main antenna beam through a set of geometric parameters shown in Figure 8.3; these parameters include the beam center<sup>2</sup>,  $\{I_{\text{SKY}}, \phi_{\text{SKY}}\}$ , where the angle  $\phi_{\text{SKY}}$  is measured positive, clockwise with respect to the U-axis<sup>3</sup>, the beam size,  $\text{HPBW}_1 \times \text{HPBW}_2 = 2a_0 \times 2b_0$  (in the Figure 8.3), since the beam is elliptical due to the antenna optics, and finally, the angle  $\phi_0$ , between the major semi axis of the ellipse and the U-axis.

Based on a non-linear normalized Airy pattern model with elliptical cross section<sup>4</sup> we obtained the set of parameters for the multi beam based on the CSIRO Coax 22.0x22.8 cm and CSIRO TE<sub>11</sub> mode 25.0x26.0 cm horns shown in Table 8.1, respectively. The first column in the table refers to

<sup>2</sup> The highest antenna gain point in the pattern in polar coordinates.

<sup>3</sup> The antenna optical axis points in the direction of  $\mathbf{U} \times \mathbf{V}$ , into the page.

<sup>4</sup>  $|Airy(u, v)|^2 = \left| 2 \frac{J_1(kr(u, v))}{kr(u, v)} \right|^2$ , where,  $kr(u, v) = k \sqrt{a^2 [(u - u_0) \cos \phi_0 - (v - v_0) \sin \phi_0]^2 + b^2 [(u - u_0) \sin \phi_0 + (v - v_0) \cos \phi_0]^2}$

Pixel #0, (first row in orange), and the following rows correspond to 7 angular positions<sup>5</sup> for pixels around the center feed/pixel in the focal plane from 0° to 180°, in steps of 30°.

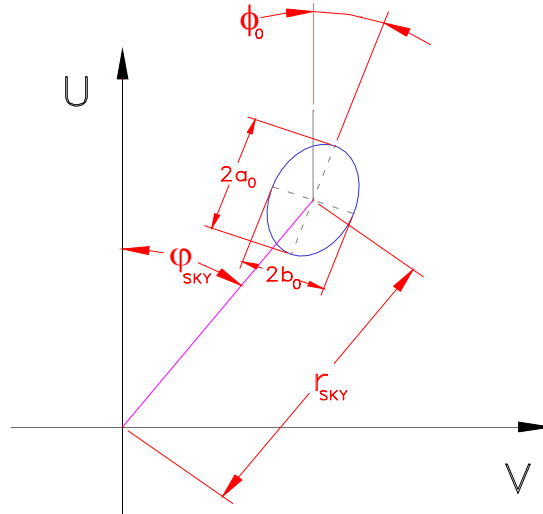


Figure 8.3 Antenna Far Field Multi-Beam Parameters

The values presented in these tables represent a best fit for each individual pattern data down to the -7.0 dB level with respect to the beam maximum. The calculated average beam size for Pixels >0 is 227 x 201 arcsec for the coaxial 22.0 x 22.8 cm feed, and 232 x 204 arcsec for the TE<sub>11</sub> 25.0 x 26.0 cm feed, respectively. The average distance between Pixels >0 and the central beam is 312 arcsec for the coaxial 22.0 x 22.8 cm feed, and 361 arcsec for the TE<sub>11</sub> 25.0 x 26.0 cm feed, i.e., 1.46 and 1.66 times the average beam size, for these two feeds respectively.

Table 8.1 Far Field Antenna Beam Parameters for a Multi Beam System at 1.375 GHz based on the Coax Horn 22.0x22, on the left, and on the TE<sub>11</sub> mode Horn 25.0 x 26.0 cm, on the right

Feed Type	Coax	Aperture		Spacing		X- Offset	
		22 cm	22.8 cm	22.8 cm	2.4 cm		
$\Phi_{FPL}$	HPBW <sub>1</sub>	HPBW <sub>2</sub>	Angle	Position	Position		
	[arcsec]	[arcsec]	$\Omega$	$r_{SKY}$	$\Phi_{SKY}$		
	[arcsec]	[arcsec]	[deg]	[arcsec]	[deg]		
Pix 0	227	198	0	35.68	0.00		
0°	230	204	0	371.77	0.00		
30°	228	204	3	356.59	-24.54		
60°	226	204	0	321.10	-52.28		
90°	225	202	-4	290.45	-84.99		
120°	226	199	-7	285.02	-119.79		
150°	224	202	-4	290.45	-84.99		
180°	231	195	0	304.32	180.00		

Feed Type	TE <sub>11</sub>	Aperture		Spacing		X- Offset	
		25 cm	26.0 cm	26.0 cm	2.7 cm		
$\Phi_{FPL}$	HPBW <sub>1</sub>	HPBW <sub>2</sub>	Angle	Position	Position		
	[arcsec]	[arcsec]	$\Omega$	$r_{SKY}$	$\Phi_{SKY}$		
	[arcsec]	[arcsec]	[deg]	[arcsec]	[deg]		
Pix 0	230	201	0	39.87	0.00		
0°	236	206	0	421.46	0.00		
30°	234	207	5	404.70	-24.72		
60°	229	208	4	364.48	-52.62		
90°	227	206	-5	329.95	-85.38		
120°	230	202	-9	324.20	-120.14		
150°	234	198	-6	338.74	-151.74		
180°	236	197	0	346.55	180.00		

Figures 8.4 and 8.5 show the sky footprint for the Arecibo multi beam system based on a coaxial 22.0 x 22.8 cm feed and a TE<sub>11</sub> 25.0 x 26.0 cm feed, respectively.

<sup>5</sup> In its standard position, Pixel #1 is at  $\Phi_{FPL}=30^\circ$ , and Pixel #2 is at  $\Phi_{FPL}=90^\circ$ , etc.

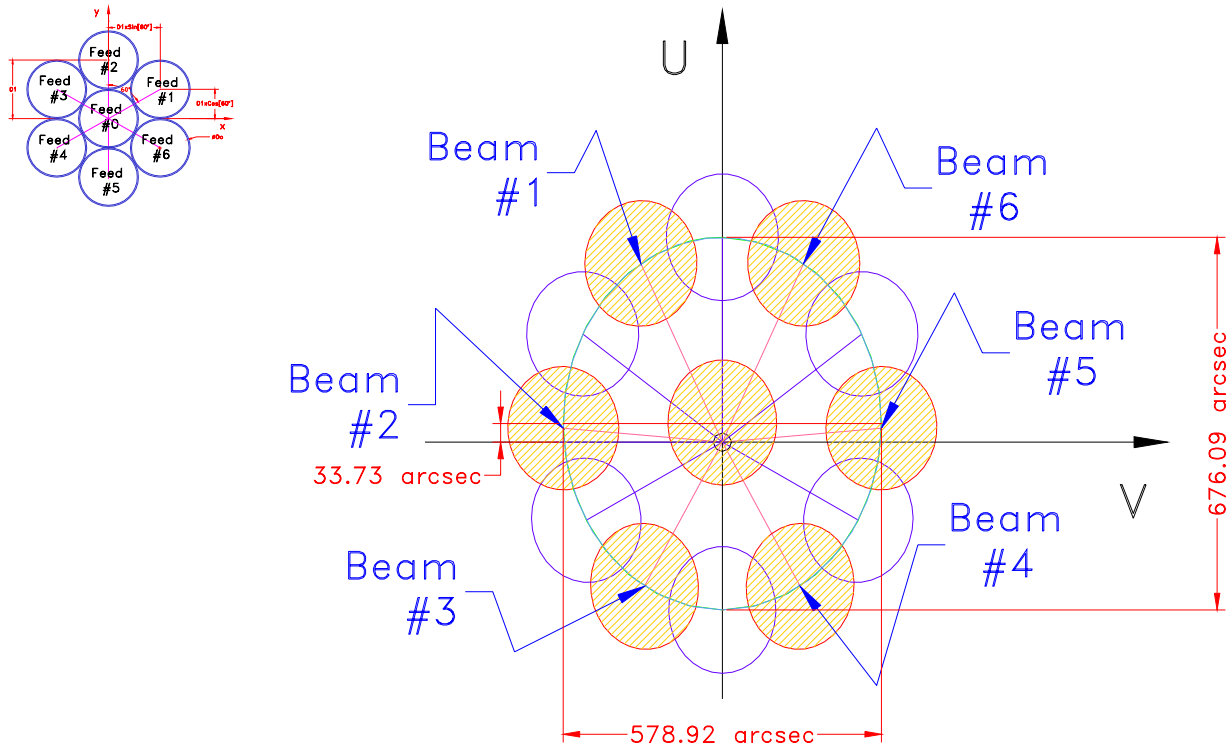


Figure 8.4 Sky Footprint Geometry for a Coax 22.0x22.8cm Horn based Arcicibo Multi Beam

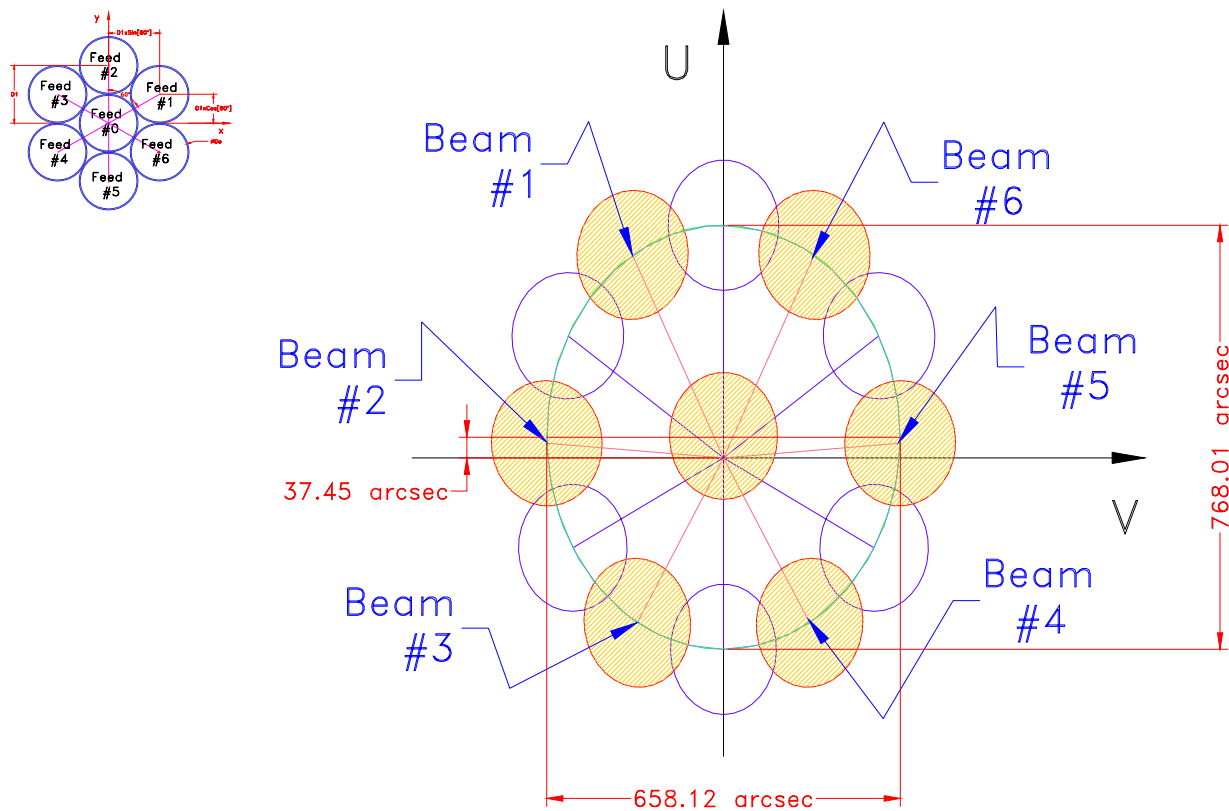


Figure 8.5 Sky Footprint Geometry for a TE<sub>11</sub> 25.0x26.0 cm Horn based Arcicibo Multi Beam

These figures show the location and shapes of all beams in the standard configuration, as well as when the multi beam is rotated by 30° in the focal plane. The center of the elliptical path is off from the antenna optical axis by 33.73 arcsec in the case of the coaxial 22.0 x 22.8 cm feed and 37.45 arcsec for the TE<sub>11</sub> 25.0 x 26.0 cm feed.

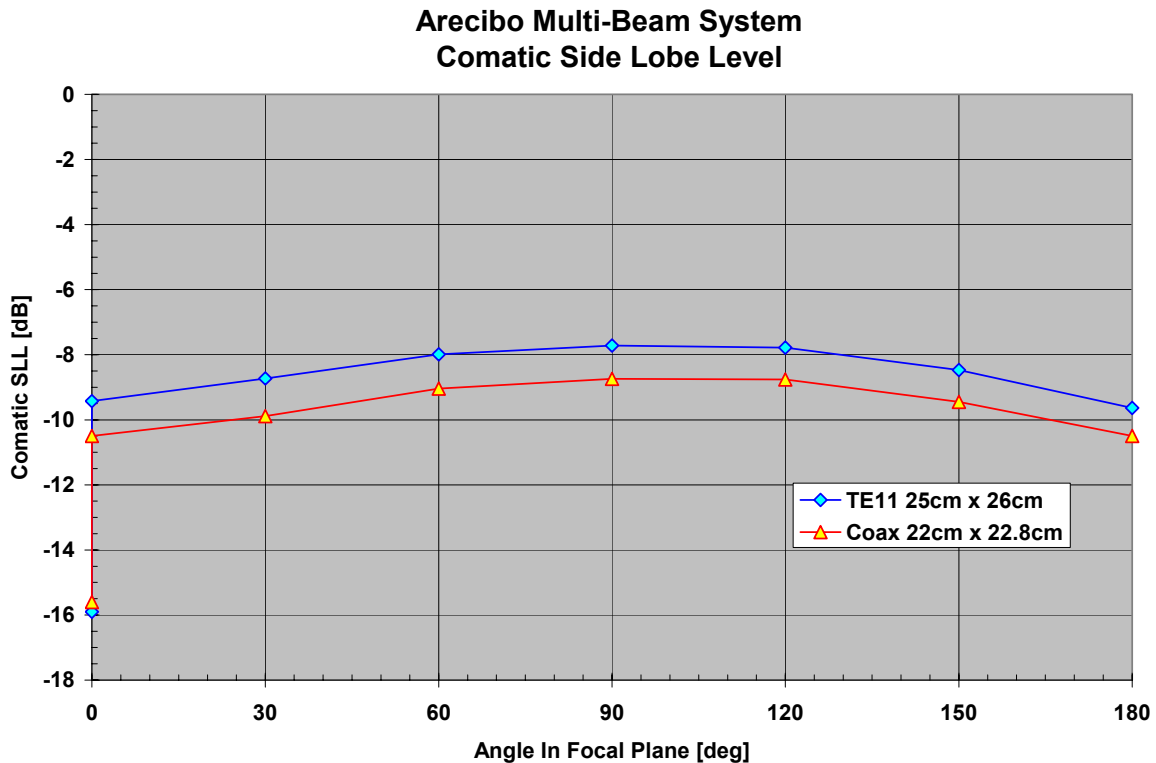
The sky footprint track could be best fitted to an ellipse whose parameters are shown below in Table 8.2. We found that the ellipse size has a linear dependence on the feed center-to-center separation, while the eccentricity remains almost constant.

**Table 8.2 Parameters of Multi Beam Sky Footprint Ellipse**

Feed Type		U-Offset	Major	Minor	Eccentricity
		$\Delta U$	2xa	2xb	$\epsilon$
		Arcsec	arcsec	arcsec	
CSIRO Coax	22.0x22.8 cm	33.73	676.09	578.92	0.5165
CSIRO TE <sub>11</sub>	25.0x26.0 cm	37.45	768.01	658.12	0.5155

### 8.3 Multi Beam Comatic Levels

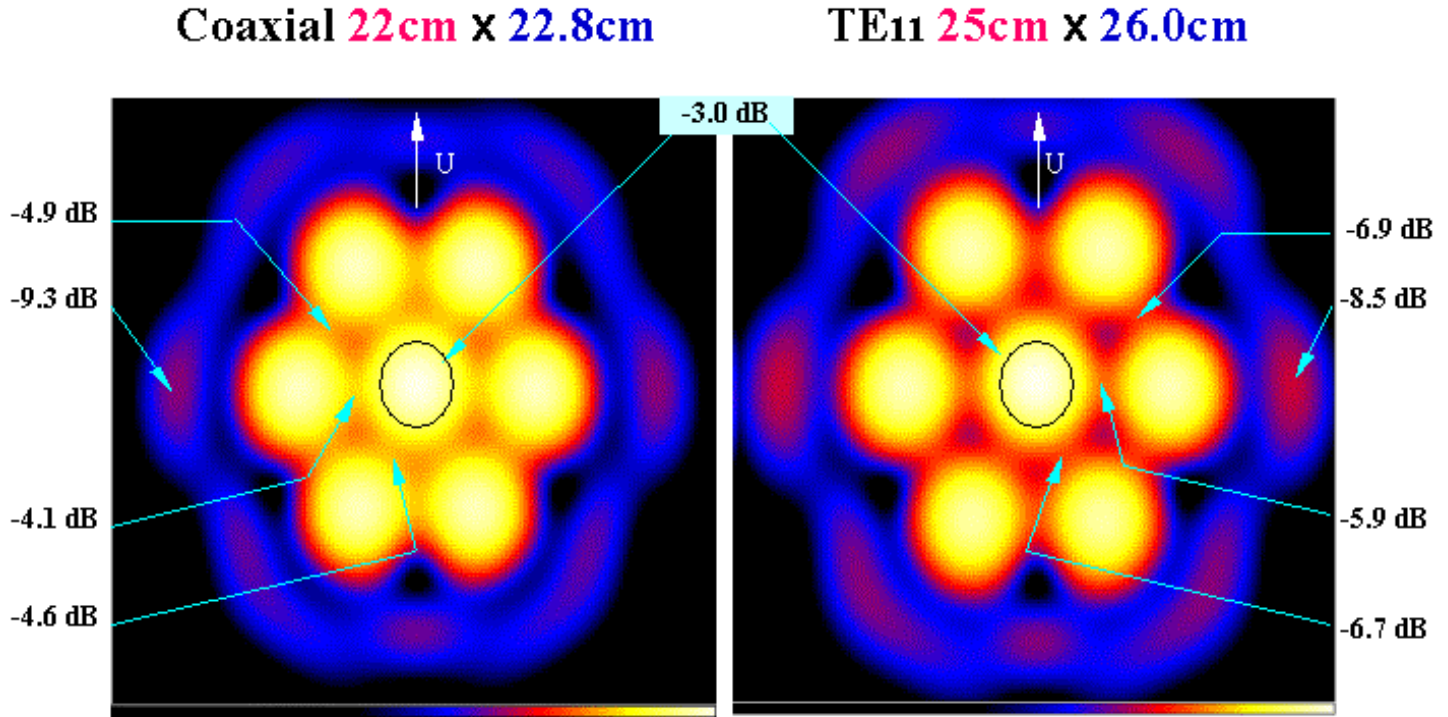
An important parameter for imaging purposes for the Multi Beam in the Arecibo Gregorian optics is the coma level, which is already evident in Figure 8.2. The calculated comatic side lobe level (SLL) for the coaxial 22.0 x 22.8 cm feed, shown in Figure 8.6, varies from -10.5 dB to -8.7 dB, with the minimum value when the feed angular position in the focal plane is at 0° or 180°, and the maximum when is at 90°. The comatic SLL For the TE<sub>11</sub> 25.0 x 26.0 cm feed vary between -9.5 dB, at 0° or 180°, and -7.7 dB, at 90°. The SLL for the central pixel is very similar for both feed types of the order of -15.8 dB.



**Figure 8.6 Comatic Side Lobe Levels for the Arecibo Multi Beam System**

### 8.4 Total Multi Beam Incoherent Pattern

When we add all the beam patterns incoherently we obtain the picture shown in Figure 8.7 for the coaxial 22x22.8 cm horn, on the left, and for the TE<sub>11</sub> mode 25x26 cm horn, on the right. The figure shows the 3 dB contour level for both horns at the center pixel, and power levels at the overlapping points and the highest coma level. Each picture corresponds to a region in the sky of 25-arcmin x 25-arcmin.



**Figure 8.7 Total Multi Beam Incoherent Antenna Pattern**

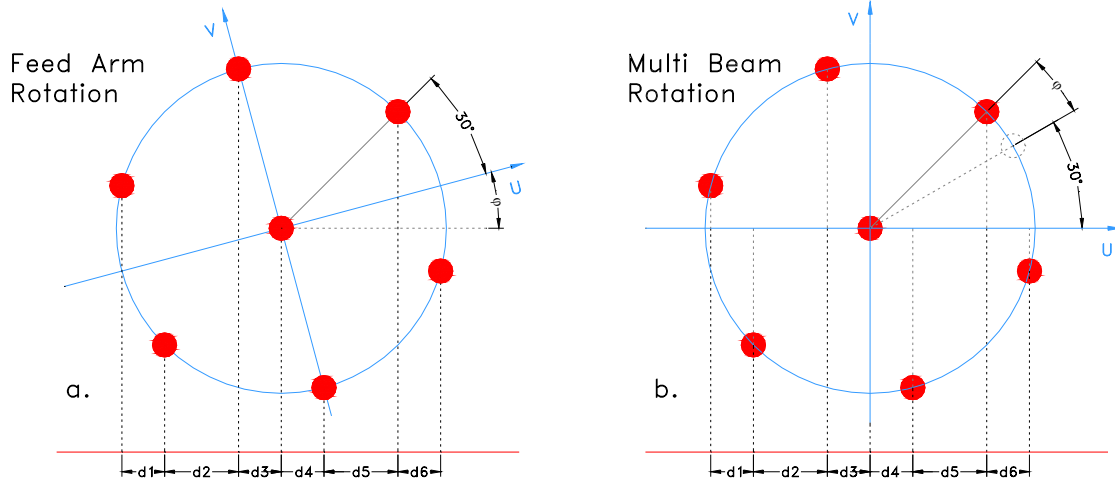
In average, the overlapping power level is about -4.5 dB for the coaxial 22x22.8 cm horn and -6.5 dB for the TE<sub>11</sub> mode 25x26 cm horn.

### 8.5 Drift Scan Sampling and Multi Beam

Figure 8.8 shows two possible methods for sampling by drift scan; one possibility is to rotate the feed arm to an optimum angle for which the separation between tracks is the same (or almost the same). Another possibility is to rotate the multi beam systems itself, again trying to obtain equal track spacing. It is very likely that a combination of these two methods be used when the multi beam system is operational.

By using the differences between track spacing, i.e.,  $d_1, d_2, \dots, d_6$ , shown in Figure 8.8, we define the following error function to determine the inequality in the projected track spacing, and which goes to zero when all projected paths are identical.

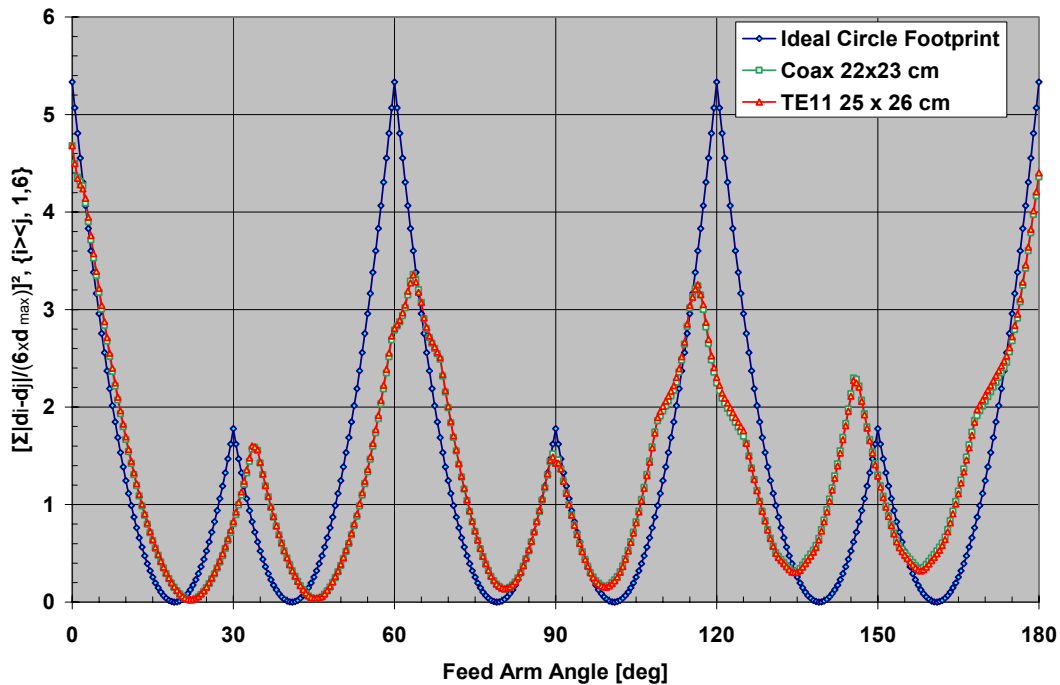
$$f(d_i) = \left( \sum_{\substack{i,j=1,\dots,6 \\ i \neq j}} \frac{|d_i - d_j|}{6 d_{max}} \right)^2$$



**Figure 8.8 Drift Scan Sampling Methods: (a). Feed arm rotation, (b). Multi Beam rotation**

Let us analyze the Feed Arm Rotation method for drift scan sampling: first, in the ideal case of a perfect circular path, the function,  $f(d_i)$  is exactly zero<sup>6</sup> at  $\phi=19.11^\circ$ ,  $60^\circ\pm 19.11^\circ$ , etc, shown in blue in Figure 8.9. Now, for an elliptical footprint path, such the one shown in Figure 8.10, the function minimums depend on the path eccentricity and beam positions on the path. For the two horns under consideration the function has the first minimum at  $\phi=22.0^\circ$ , as shown in Figure 8.9. The other minima are located at  $60^\circ\pm 22.0^\circ$ , etc, increasing monotonically.

**Arecibo Multi Beam System  
Optimum Drift Scan Angle**

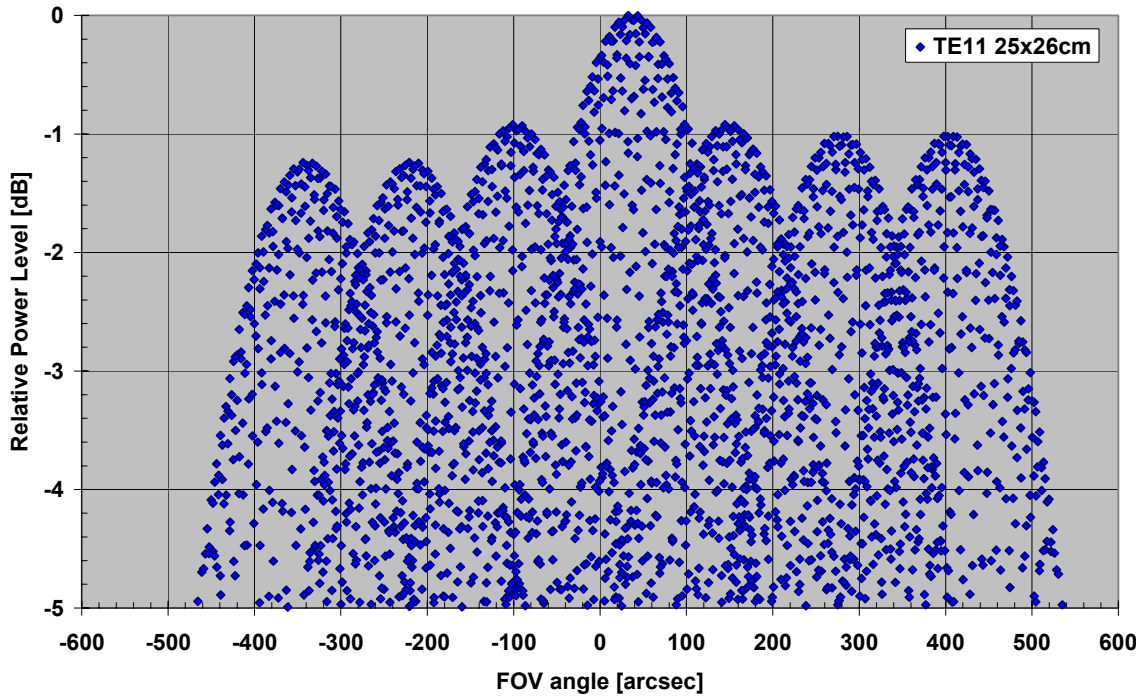


**Figure 8.9 Optimum Feed Arm rotation angle for Drift Scan Sampling**

<sup>6</sup> Germán Cortés, “Maximum Beam Separation for Multi Beam Nyquist Sampling with a Symmetric Elliptical Footprint Path”, Arecibo Focal Array Memo Series, NAIC, Cornell University, June 2002.

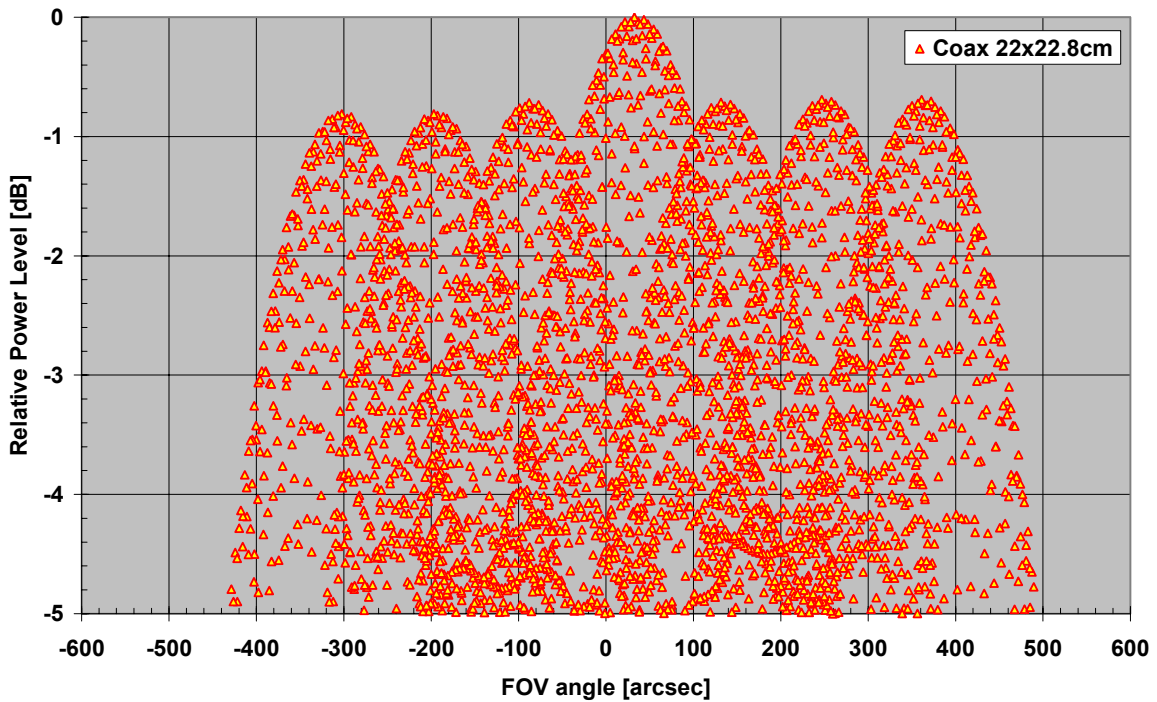


**Arecibo Multi Beam System  
Crossover Levels for Drift Scan at Optimum Angle**



**Figure 8.11 Projected patterns and Crossover levels for CSIRO TE<sub>11</sub> 25 x26 cm Horn**

**Arecibo Multi Beam System  
Crossover Levels for Drift Scan at Optimum Angle**



**Figure 8.12 Projected patterns and Crossover levels for CSIRO coaxial 22 x22.8 cm Horn**

## 9. Conclusions

We have analyzed two feed horn designs from CSIRO for the Arecibo Multi Beam System, namely, a coaxial horn with 22.0 cm aperture and a center-to-center spacing of 22.8 cm, and a stepped TE<sub>11</sub> mode horn of 25 cm aperture and center-to-center spacing of 26.0 cm

The overall study concludes that the TE<sub>11</sub> mode horn of 25 x26 cm has better performance in terms of spillover efficiency, antenna noise temperature,  $A_{\text{eff}}/T_{\text{sys}}$ , with and without the full tertiary Noise skirt.

In terms of antenna sensitivity both feed horns perform equally well for the central pixel, and the coaxial feed horn slightly better performance for the peripheral pixels.

Even though, G/T (or  $A_{\text{eff}}/T_{\text{sys}}$ ) for the coaxial 22x22.8cm improves with the tertiary Noise Skirt in place, its performance is still lower than for the TE<sub>11</sub> mode 25 x26 cm horn.

We also studied the far field imaging characteristics of both arrays, the sky footprint, beam size, coma levels. We obtained the overlapping power level between beams, as well the crossover levels for drift scan sampling.

We found that the beam spacing for these two feeds is 1.46 times the beam size for the coaxial 22.0 x 22.8 cm feed, and 1.66 times the average beam size, for TE<sub>11</sub> mode 25 x26 cm feed respectively, in both cases larger than the Nyquist sampling spacing.

We obtained that the path followed by the beams in the sky, as the array rotates in the focal plane, is elliptical. Its size depends linearly on the feed spacing in the focal plane, but these ellipses have almost constant eccentricity.

We obtained that the optimum feed arm rotation angle for drift scan sampling for these two feeds is approximately 22°.

Considering all aspects of feed horn, plus antenna performance, including perceived technical risks for the two designs, we have concluded the TE<sub>11</sub> mode horn of 25 cm aperture and 26 cm center-to-center spacing is preferred for the Arecibo multi beam feed array.

## **Appendix A.**

## **A.1 Feeds Far Field Radiation Patterns**

Figures A.1 through A.9 show the far field radiation patterns for Dr. Bird's 19.6cm coaxial horn, Parkes 24.0cm TE<sub>11</sub> mode horn, our 26.0cm TE<sub>11</sub> mode horn, and Dr. Bird's 25cm TE<sub>11</sub> mode horn.

For each horn we are presenting amplitude and phase pattern cuts at the following frequencies: 1.225 GHz, 1.375 GHz, and 1.525 GHz.

Due to the rotationally symmetry of the feeds, only two cuts of the feed's radiation pattern are necessary to analyze the overall antenna performance. Nevertheless, for completeness in this document, an additional cut at 45° is also included here, in the field amplitude figures, to show cross-polar levels.

**Dr. Bird's Coaxial feed Horn (19.6 cm diameter.)**

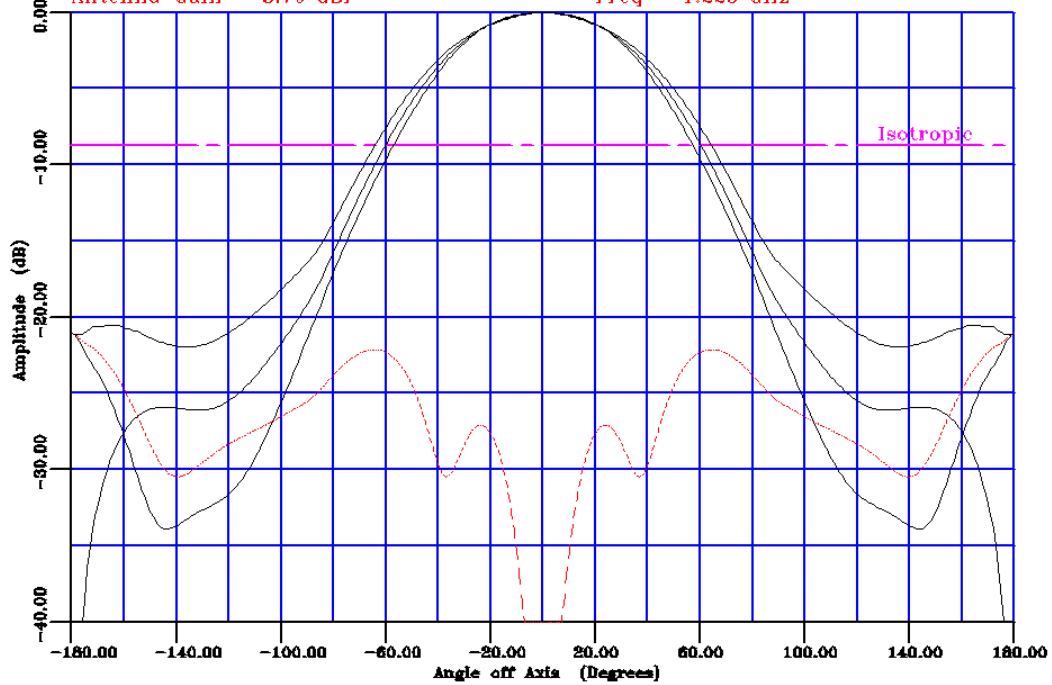
T. Bird's Coaxial Feed 19.6 cm aperture (20.4 cm C-C)

Far Field Pattern

Polarization: Vertical

Antenna Gain = 8.70 dBi

Freq = 1.225 GHz



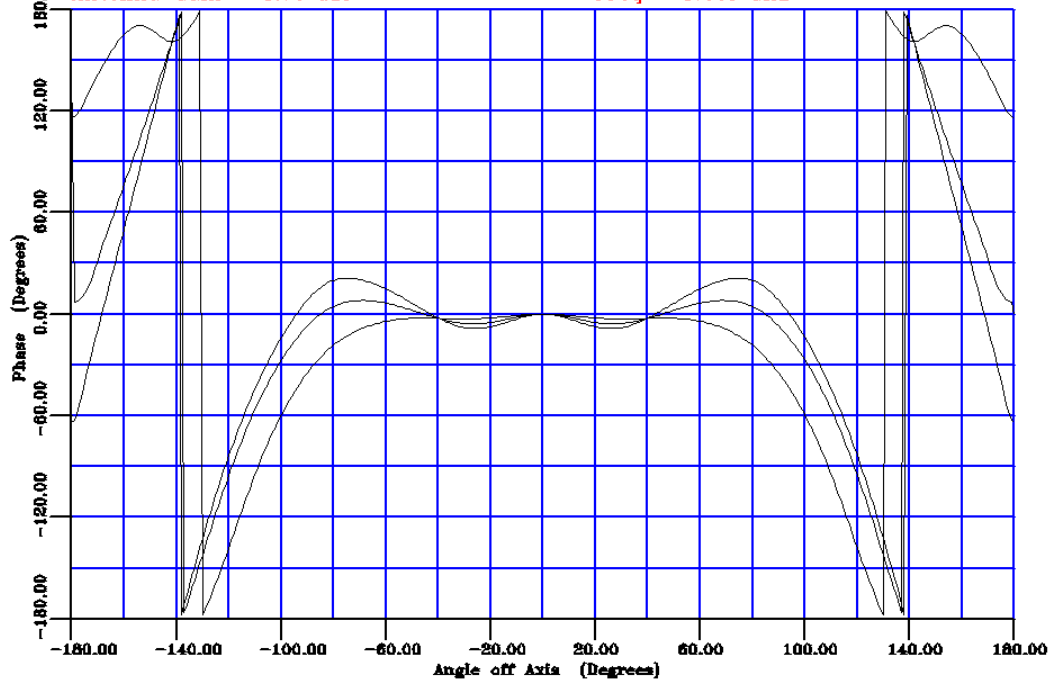
T. Bird's Coaxial Feed 19.6 cm aperture (20.4 cm C-C)

Far Field Pattern

Polarization: Vertical

Antenna Gain = 8.70 dBi

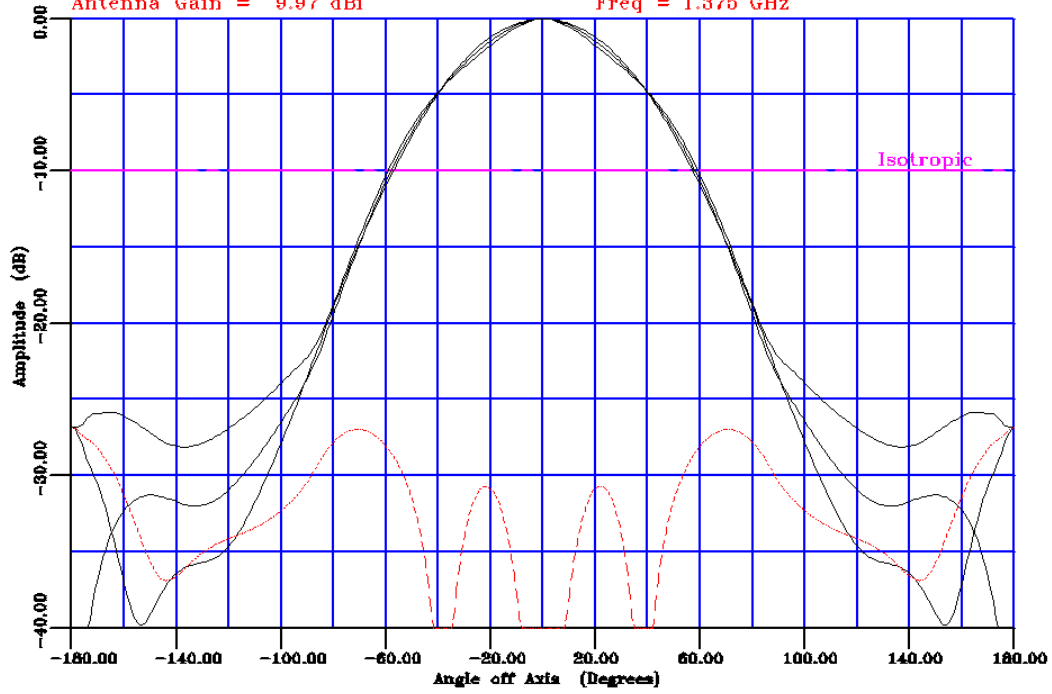
Freq = 1.225 GHz



**Figure A.1 Bird's Coax feed (19.6 cm diameter) Radiation Pattern, 1.225 GHz**

T. Bird's Coaxial Feed 19.6 cm aperture (20.4 cm C-C)

Far Field Pattern      Polarization: Vertical  
 Antenna Gain = 9.97 dBi      Freq = 1.375 GHz



T. Bird's Coaxial Feed 19.6 cm aperture (20.4 cm C-C)

Far Field Pattern      Polarization: Vertical  
 Antenna Gain = 9.97 dBi      Freq = 1.375 GHz

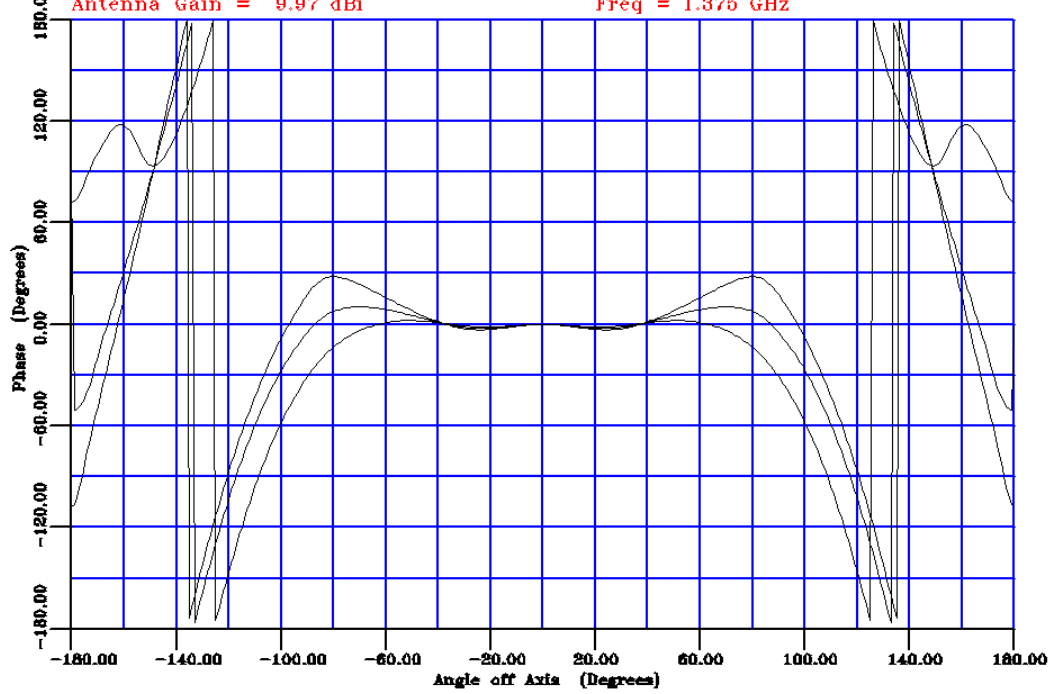
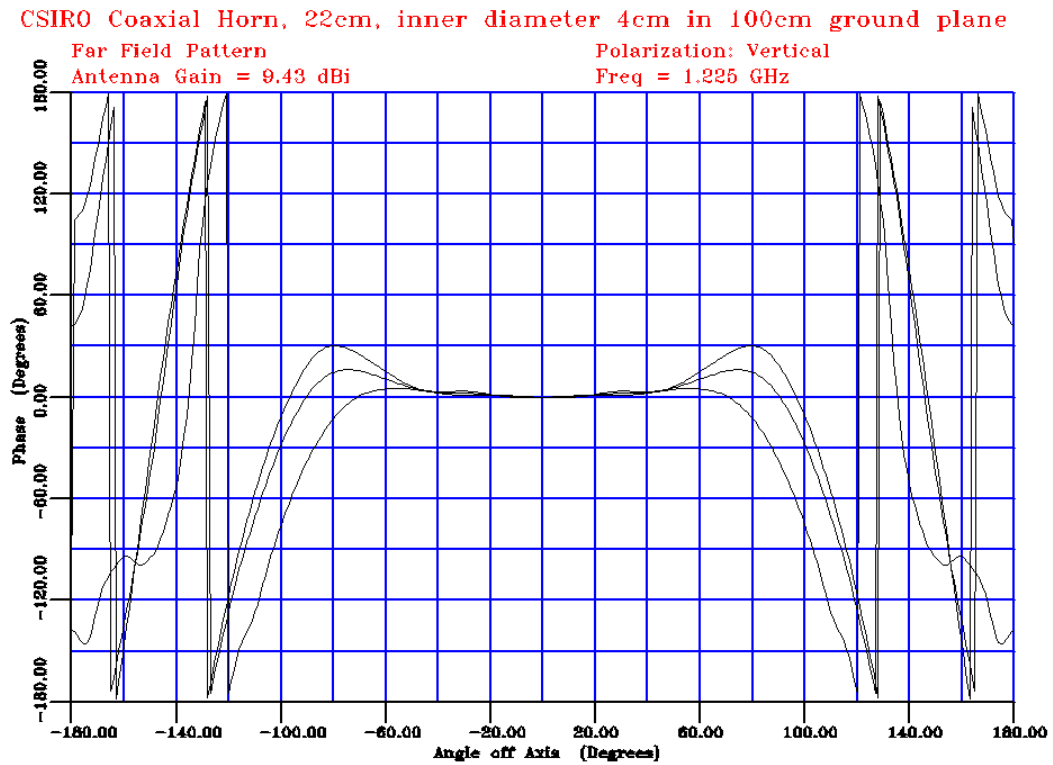
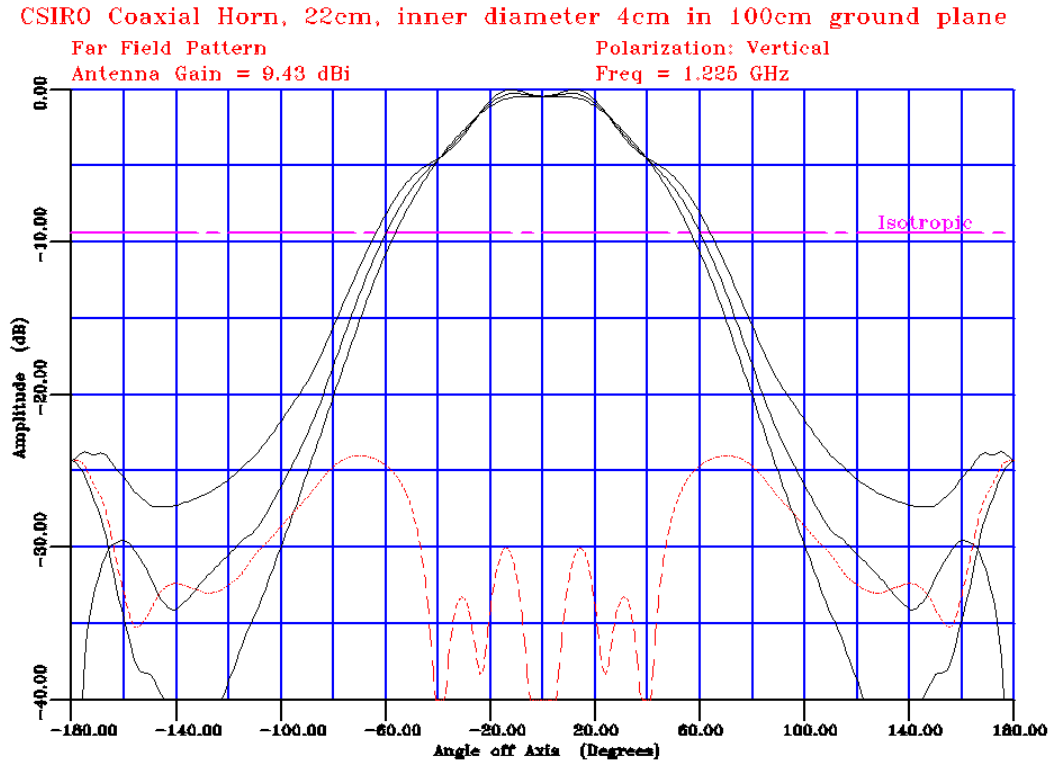


Figure A.2 Bird's Coax feed (19.6 cm diameter) Radiation Pattern, 1.375 GHz



**CSIRO Coaxial feed horn (22.0 cm diameter.)**



**Figure A.4 CSIRO Coaxial Horn (22.0 cm diam) Radiation Pattern at 1.225 GHz**

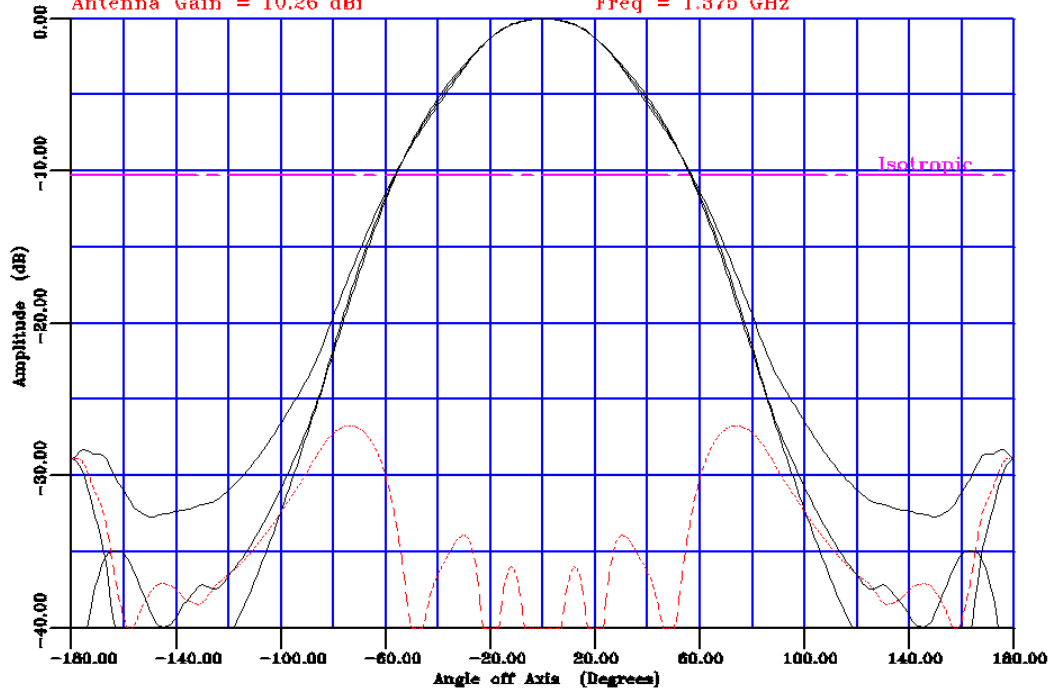
CSIRO Coaxial Horn, 22cm, inner diameter 4cm in 100cm ground plane

Far Field Pattern

Antenna Gain = 10.26 dBi

Polarization: Vertical

Freq = 1.375 GHz



CSIRO Coaxial Horn, 22cm, inner diameter 4cm in 100cm ground plane

Far Field Pattern

Antenna Gain = 10.26 dBi

Polarization: Vertical

Freq = 1.375 GHz

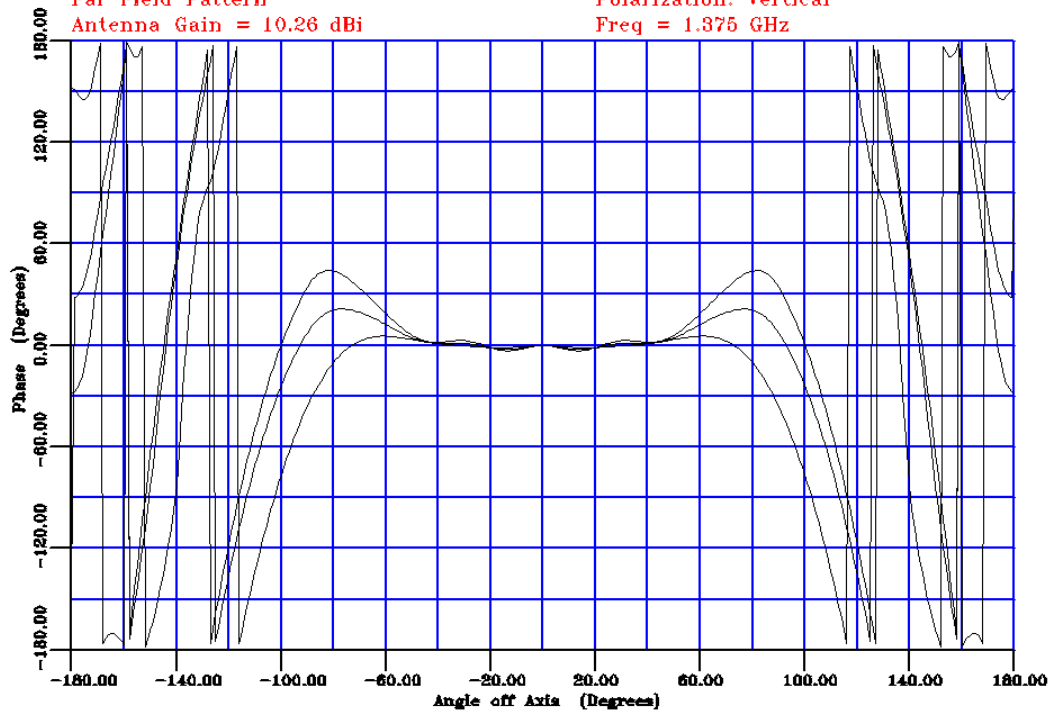


Figure A.5 CSIRO Coaxial Horn (22.0 cm diam) Radiation Pattern at 1.375 GHz

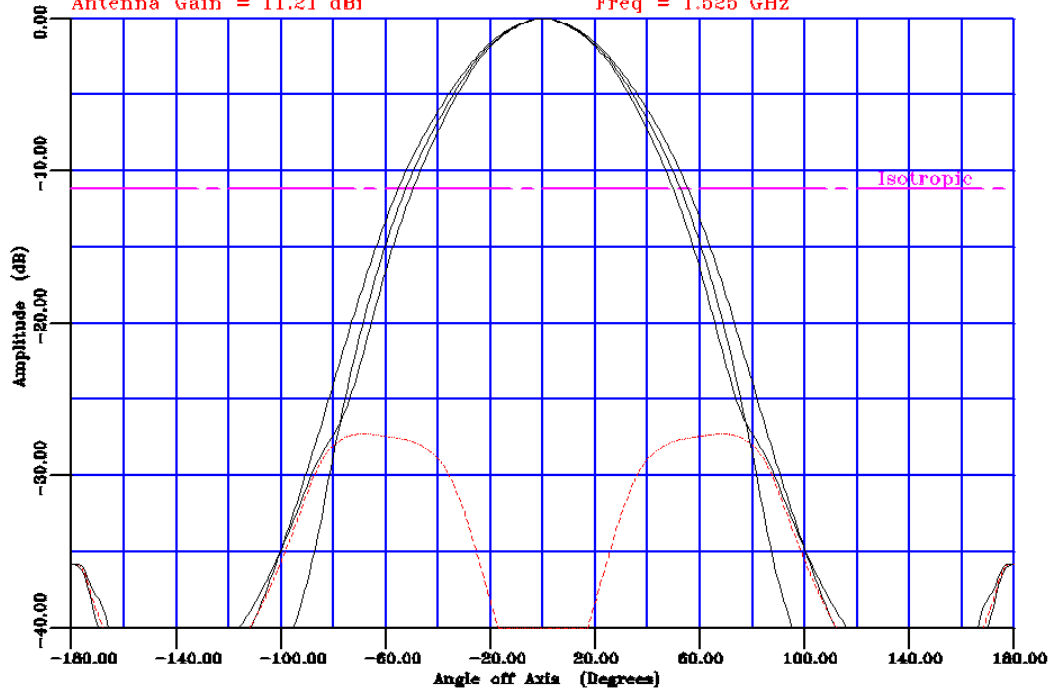
CSIRO Coaxial Horn, 22cm, inner diameter 4cm in 100cm ground plane

Far Field Pattern

Antenna Gain = 11.21 dBi

Polarization: Vertical

Freq = 1.525 GHz



CSIRO Coaxial Horn, 22cm, inner diameter 4cm in 100cm ground plane

Far Field Pattern

Antenna Gain = 11.21 dBi

Polarization: Vertical

Freq = 1.525 GHz

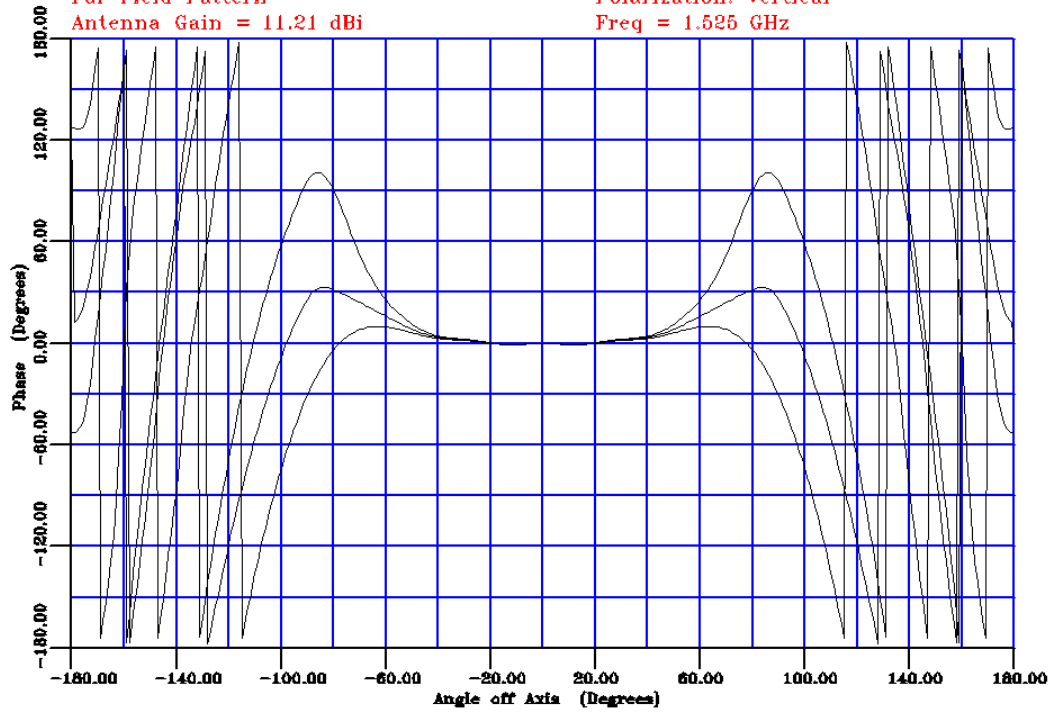
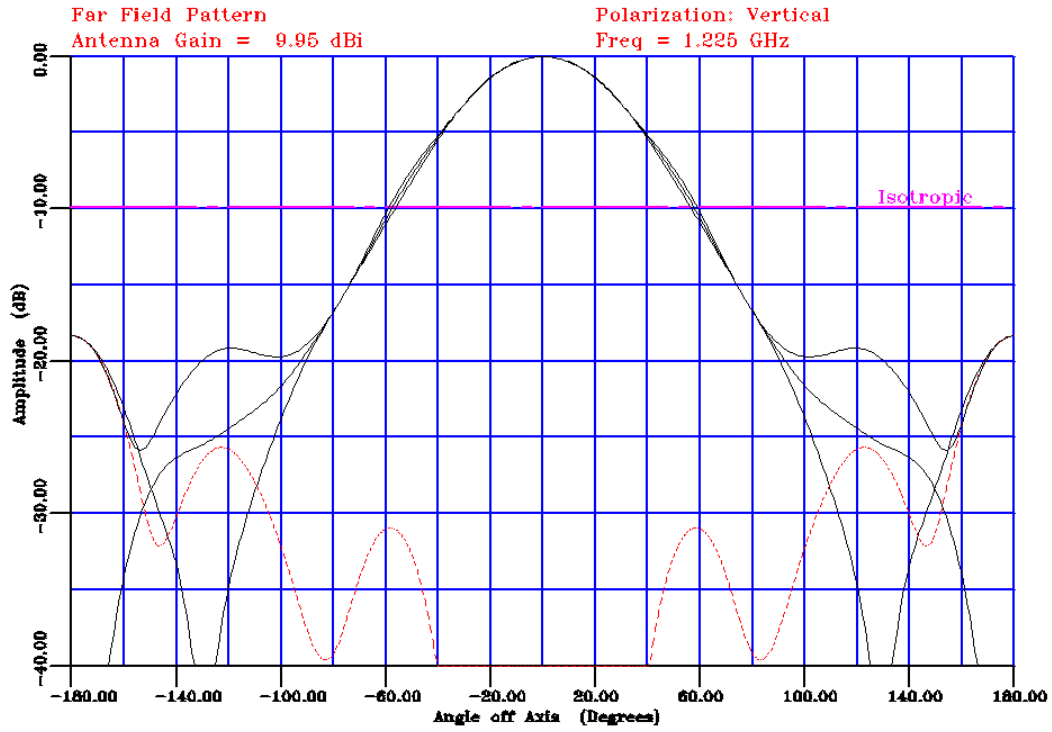


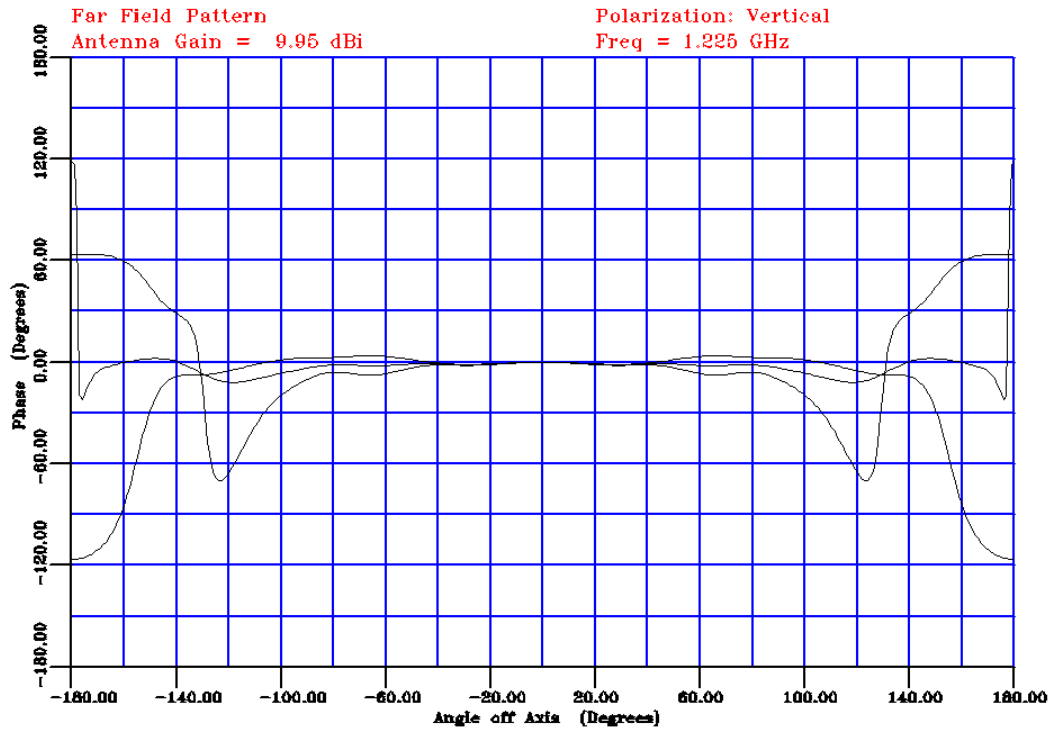
Figure A.6 CSIRO Coaxial Horn (22.0 cm diam) Radiation Pattern at 1.525 GHz

**Parkes TE11 mode feed horn (24.0 cm diameter.)**

Parkes TE11 mode Horn, 24.0 cm Aperture

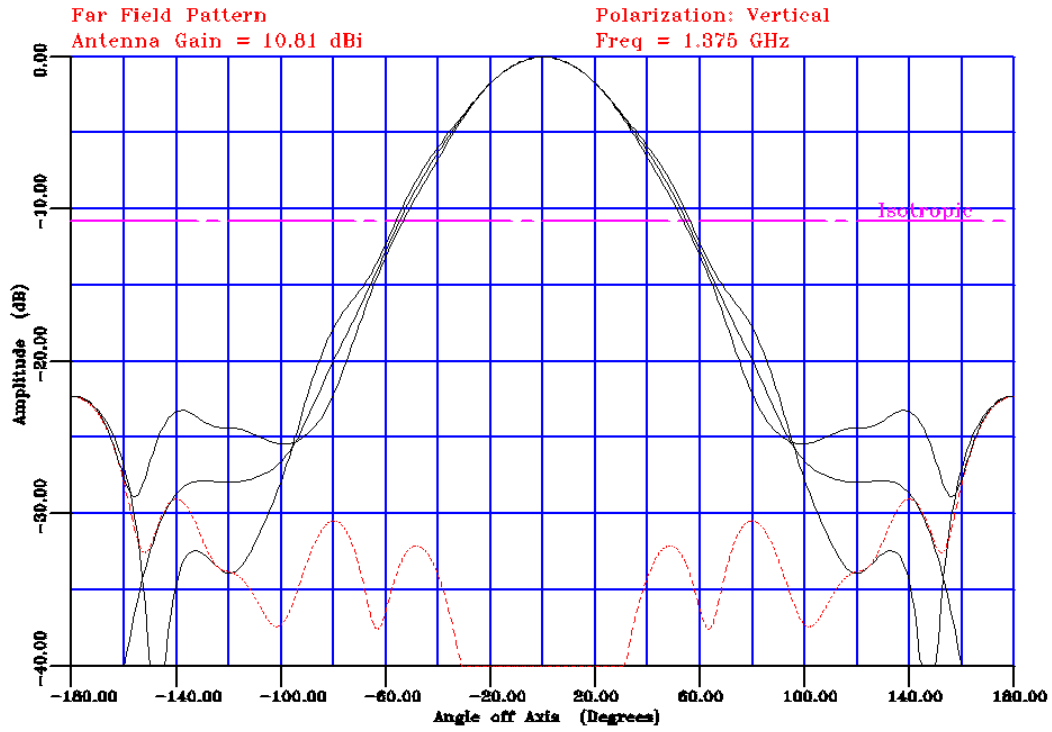


Parkes TE11 mode Horn, 24.0 cm Aperture



**Figure A.7 Parkes TE<sub>11</sub> feed (24.0 cm diam) Radiation Pattern at 1.225 GHz**

Parkes TE<sub>11</sub> mode Horn, 24.0 cm Aperture



Parkes TE<sub>11</sub> mode Horn, 24.0 cm Aperture

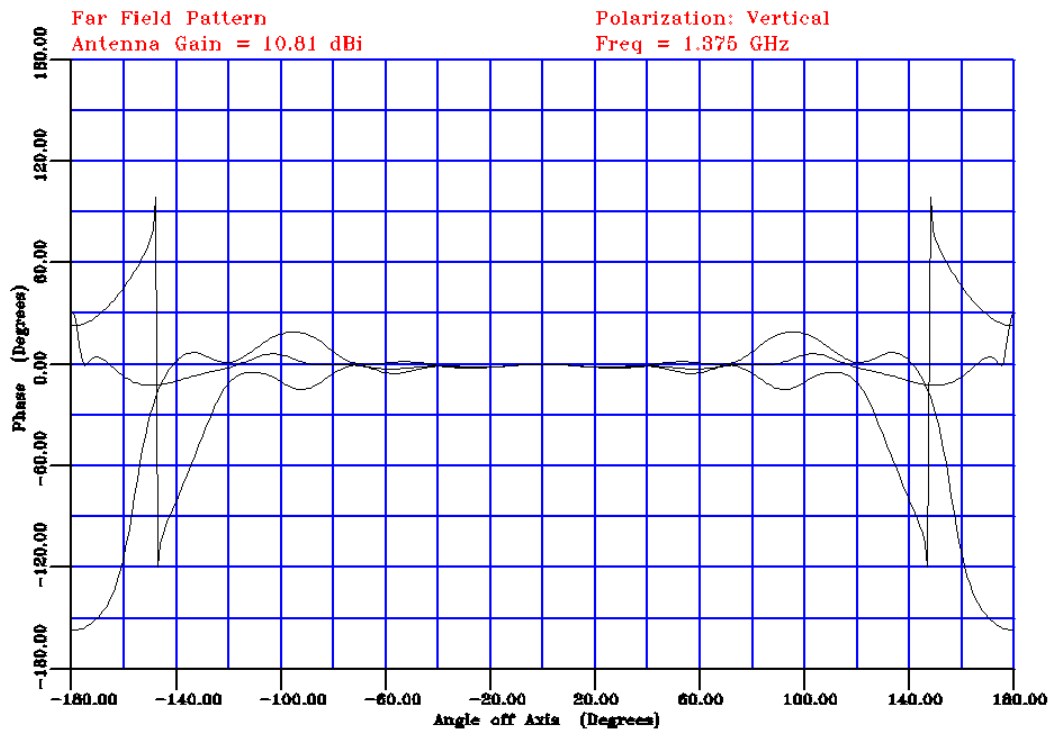
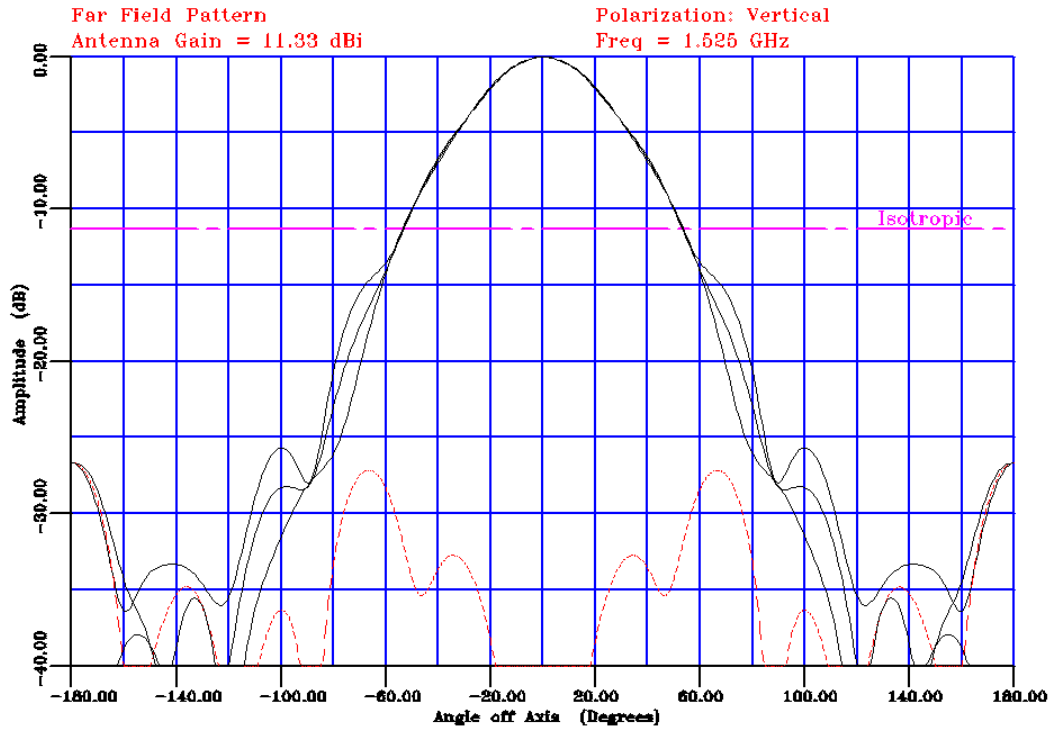


Figure A.8 Parkes TE<sub>11</sub> feed (24.0 cm diam) Radiation Pattern at 1.375 GHz

Parkes TE<sub>11</sub> mode Horn, 24.0 cm Aperture



Parkes TE<sub>11</sub> mode Horn, 24.0 cm Aperture

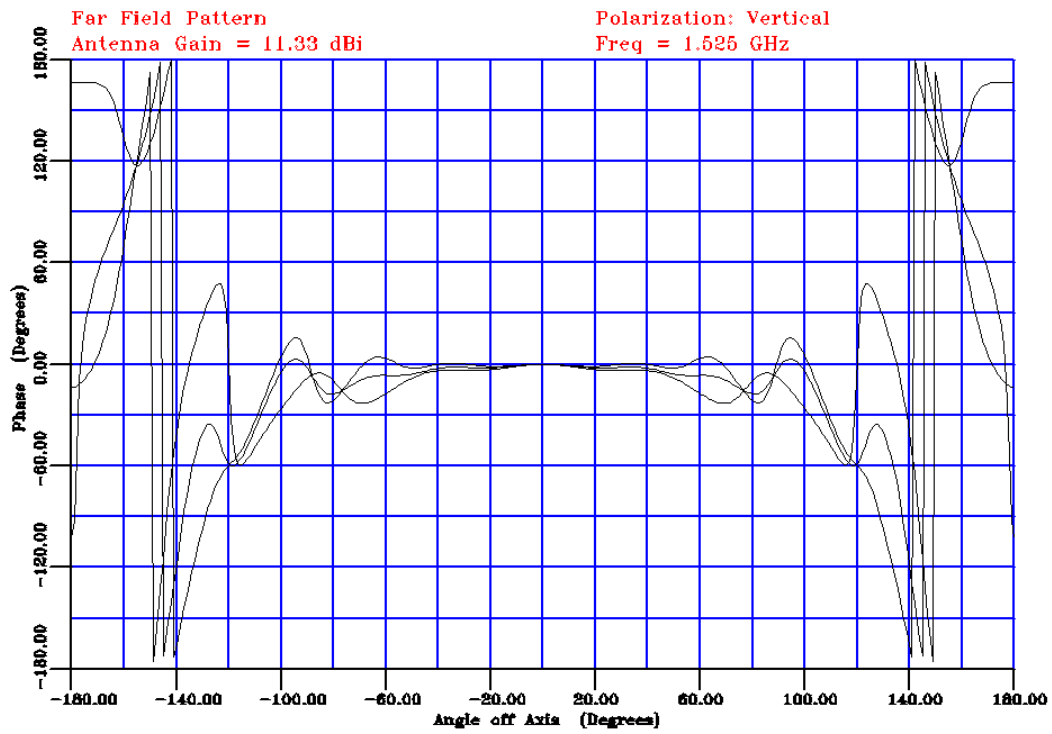


Figure A.9 Parkes TE<sub>11</sub> feed (24.0 cm diam) Radiation Pattern at 1.525 GHz

CSIRO TE<sub>11</sub> mode feed horn (25.0 cm diameter.)

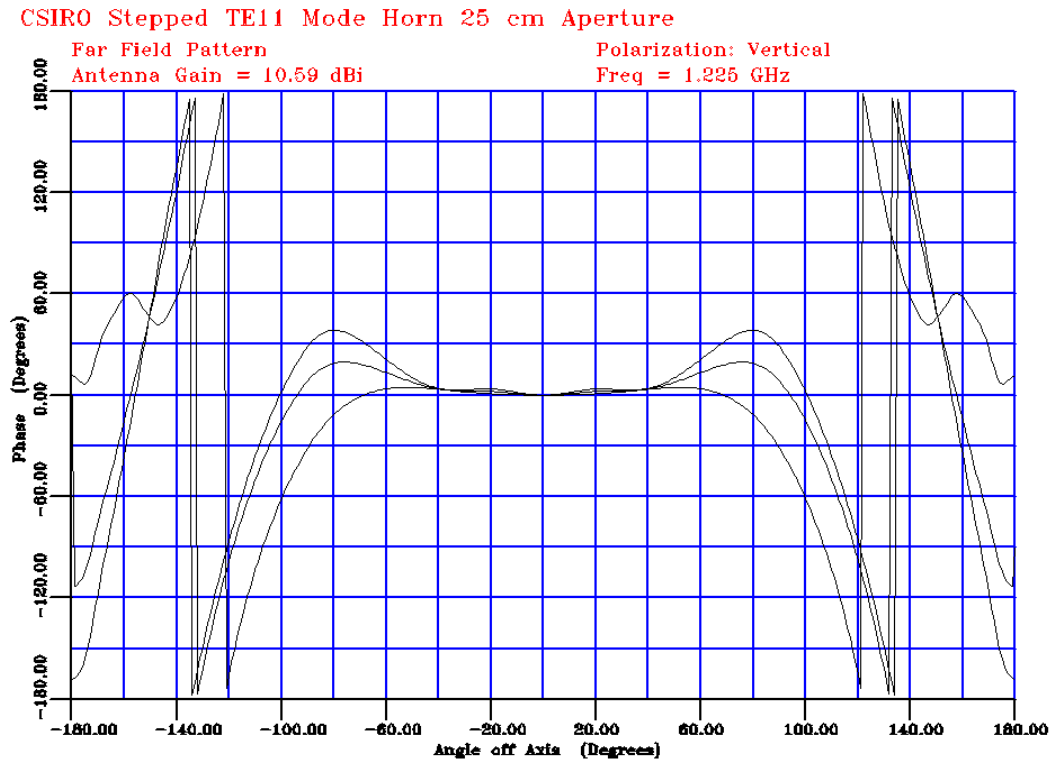
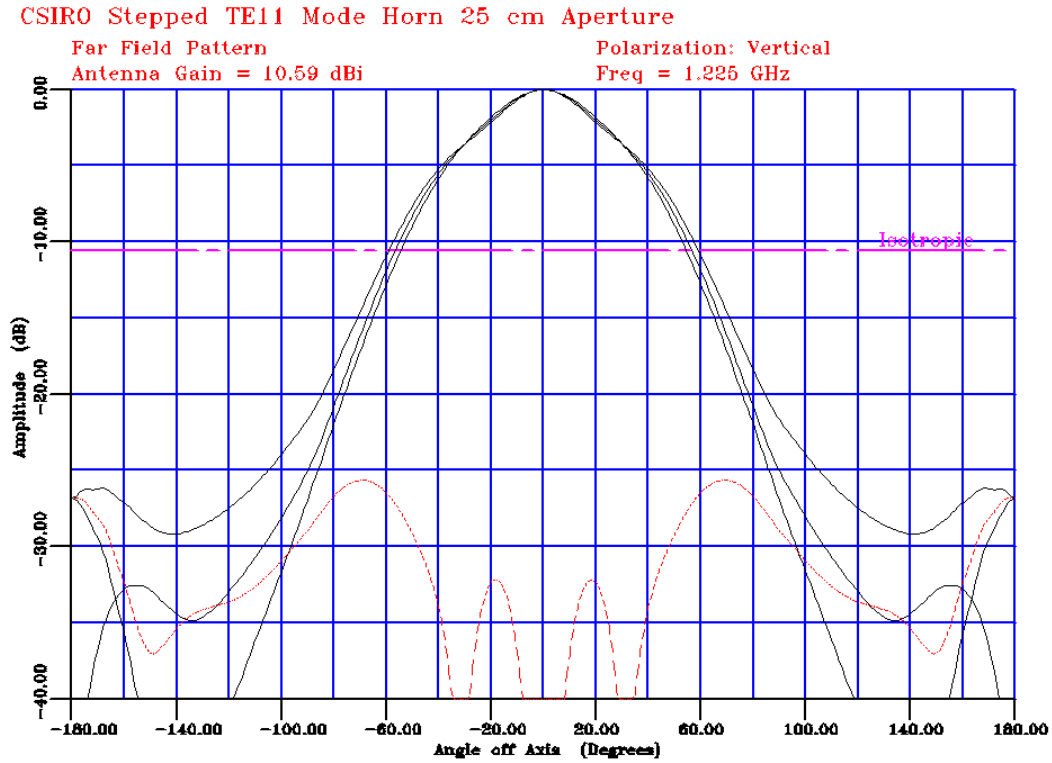


Figure A.10 CSIRO TE<sub>11</sub> mode Horn (25.0 cm) Radiation Pattern at 1.225 GHz

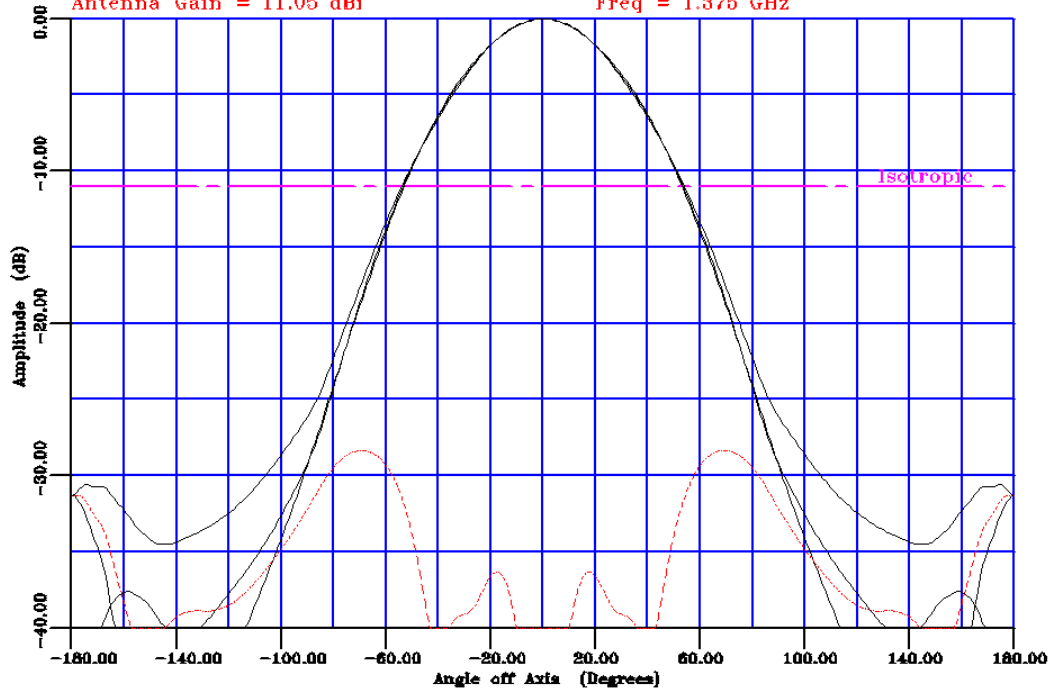
CSIRO Stepped TE<sub>11</sub> mode Horn, 25 cm Aperture

Far Field Pattern

Antenna Gain = 11.05 dBi

Polarization: Vertical

Freq = 1.375 GHz



CSIRO Stepped TE<sub>11</sub> mode Horn, 25 cm Aperture

Far Field Pattern

Antenna Gain = 11.05 dBi

Polarization: Vertical

Freq = 1.375 GHz

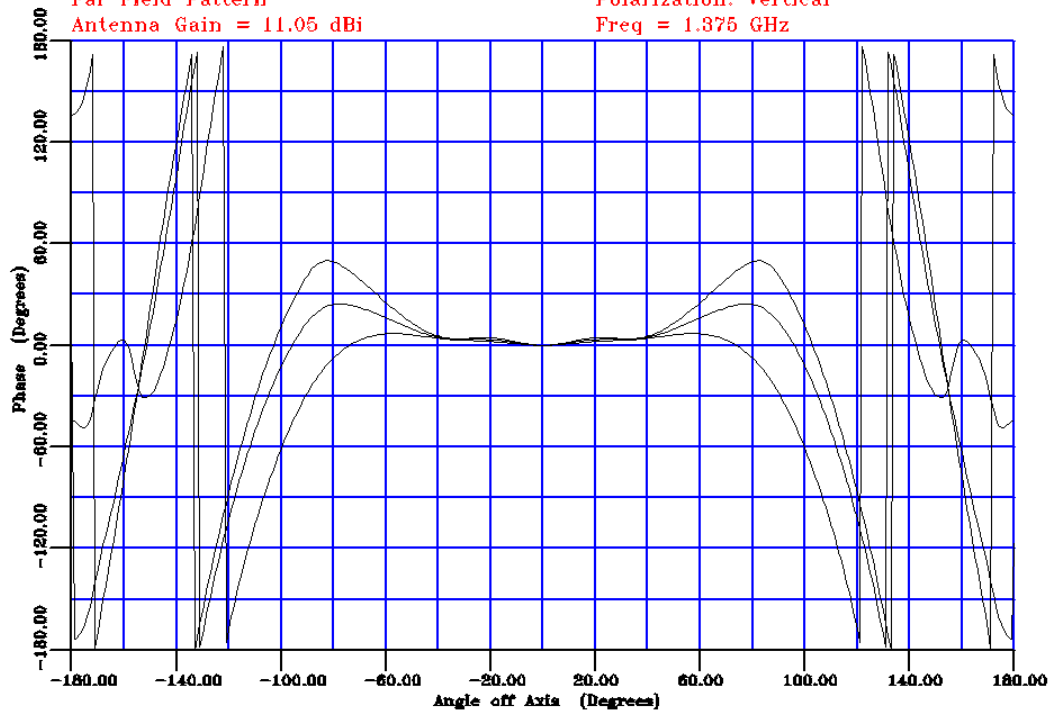


Figure A.11 CSIRO TE<sub>11</sub> mode Horn (25.0 cm) Radiation Pattern at 1.375 GHz

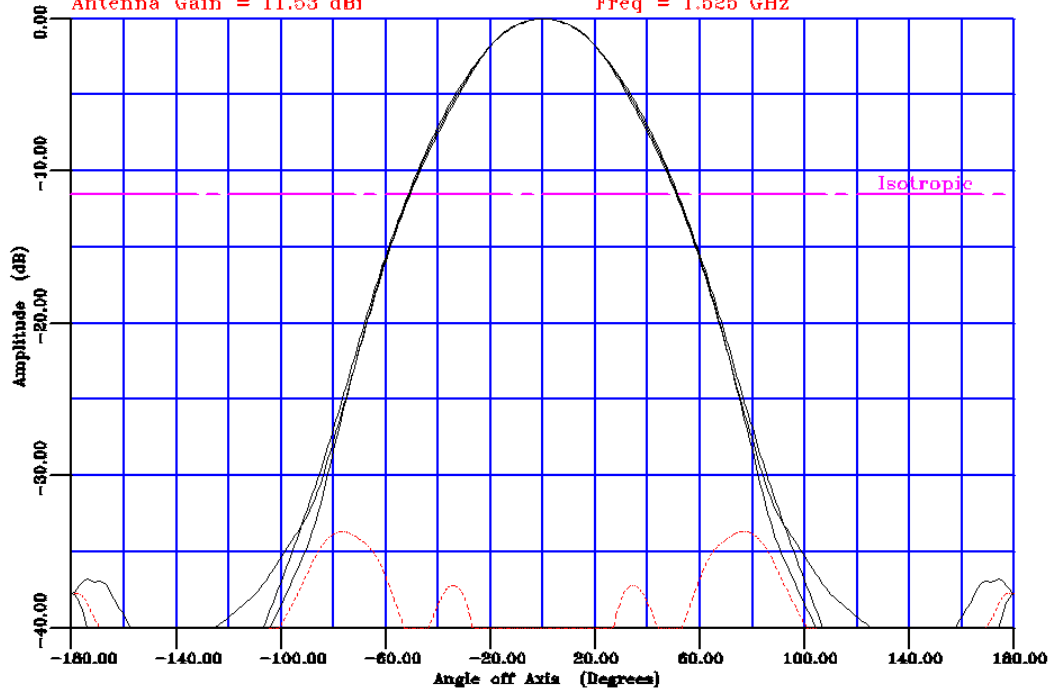
CSIRO Stepped TE<sub>11</sub> mode Horn, 25 cm Aperture

Far Field Pattern

Antenna Gain = 11.53 dBi

Polarization: Vertical

Freq = 1.525 GHz



CSIRO Stepped TE<sub>11</sub> mode Horn, 25 cm Aperture

Far Field Pattern

Antenna Gain = 11.53 dBi

Polarization: Vertical

Freq = 1.525 GHz

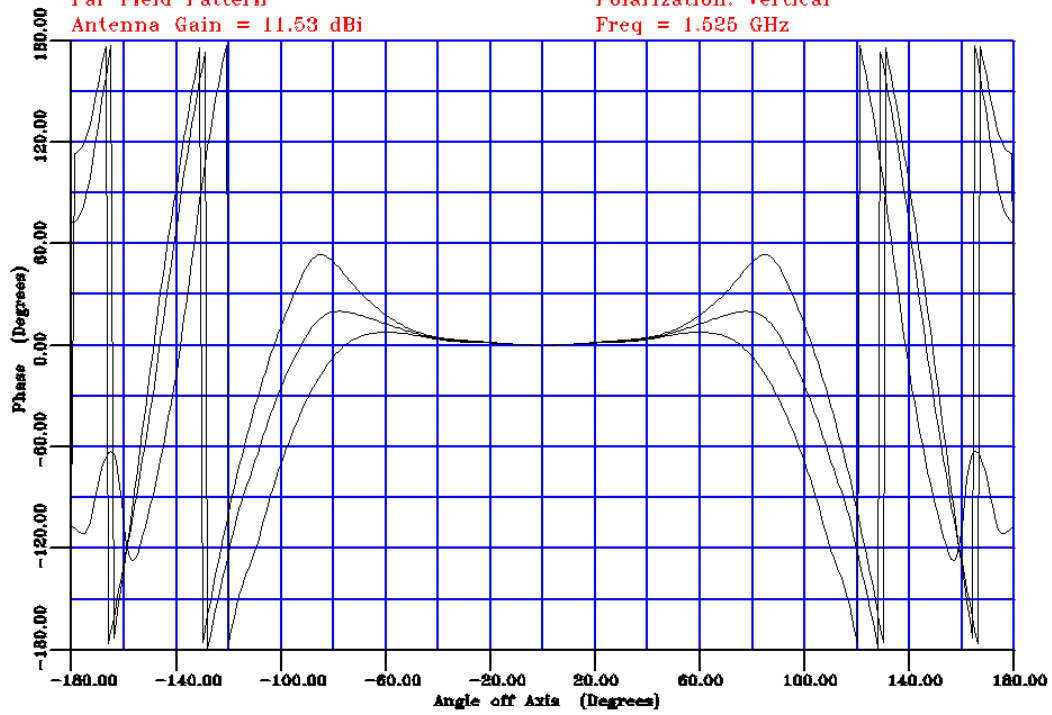


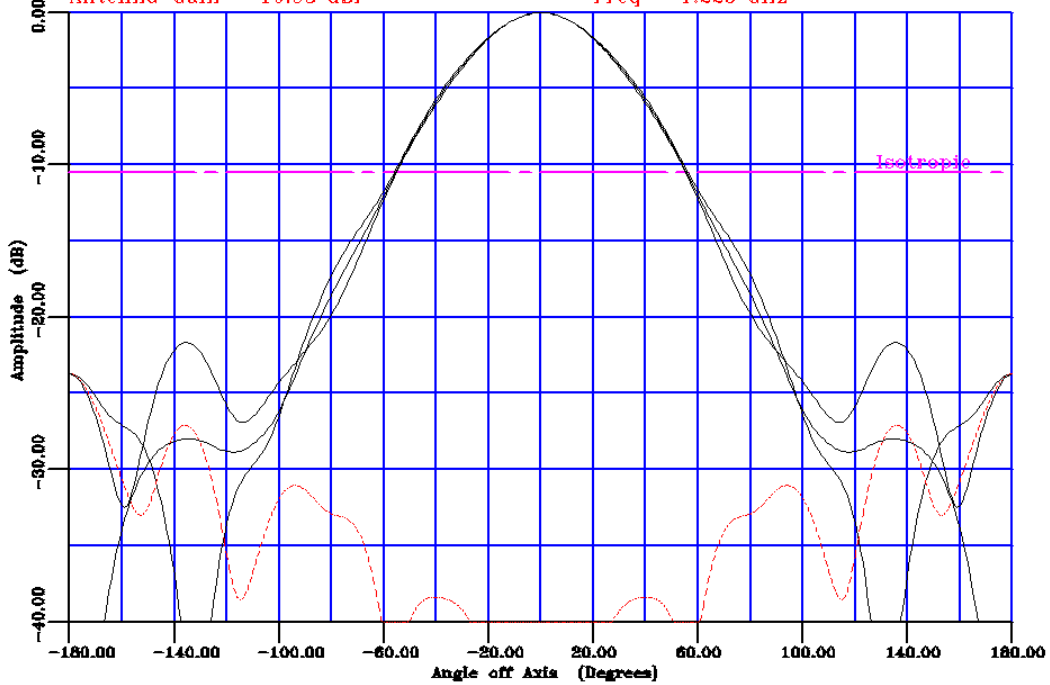
Figure A.12 CSIRO TE<sub>11</sub> mode Horn (25.0 cm) Radiation Pattern at 1.525 GHz

**TE<sub>11</sub> mode feed horn (26.0 cm diameter.)**

TE<sub>11</sub> Mode Horn, 26.0cm Aperture, Optimized

Far Field Pattern  
Antenna Gain = 10.53 dBi

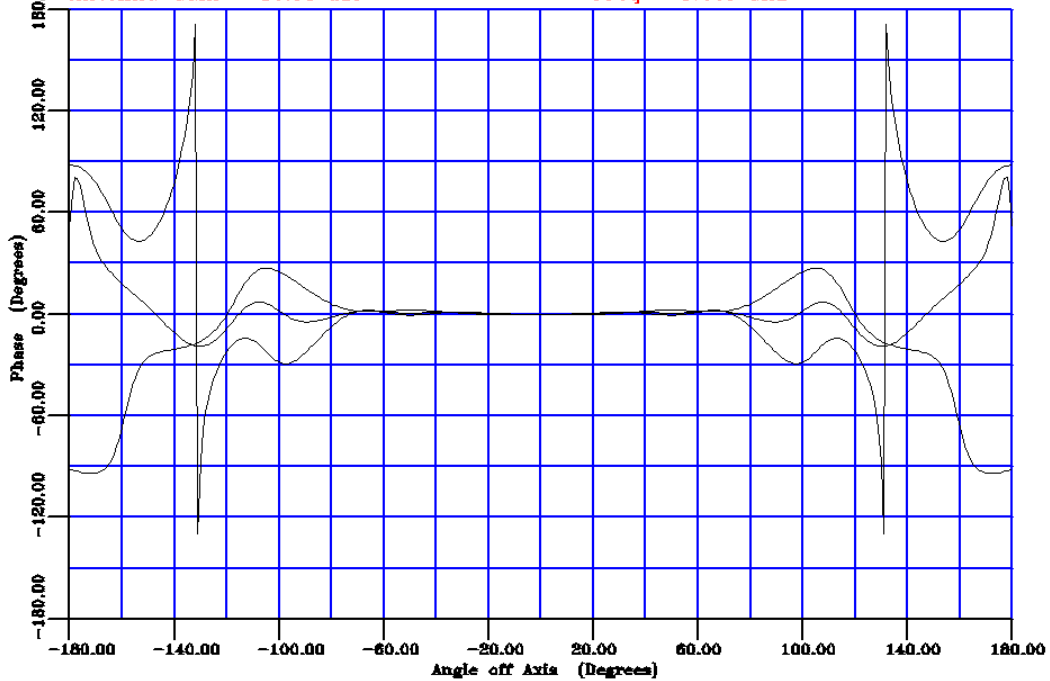
Polarization: Vertical  
Freq = 1.225 GHz



TE<sub>11</sub> Mode Horn, 26.0cm Aperture, Optimized

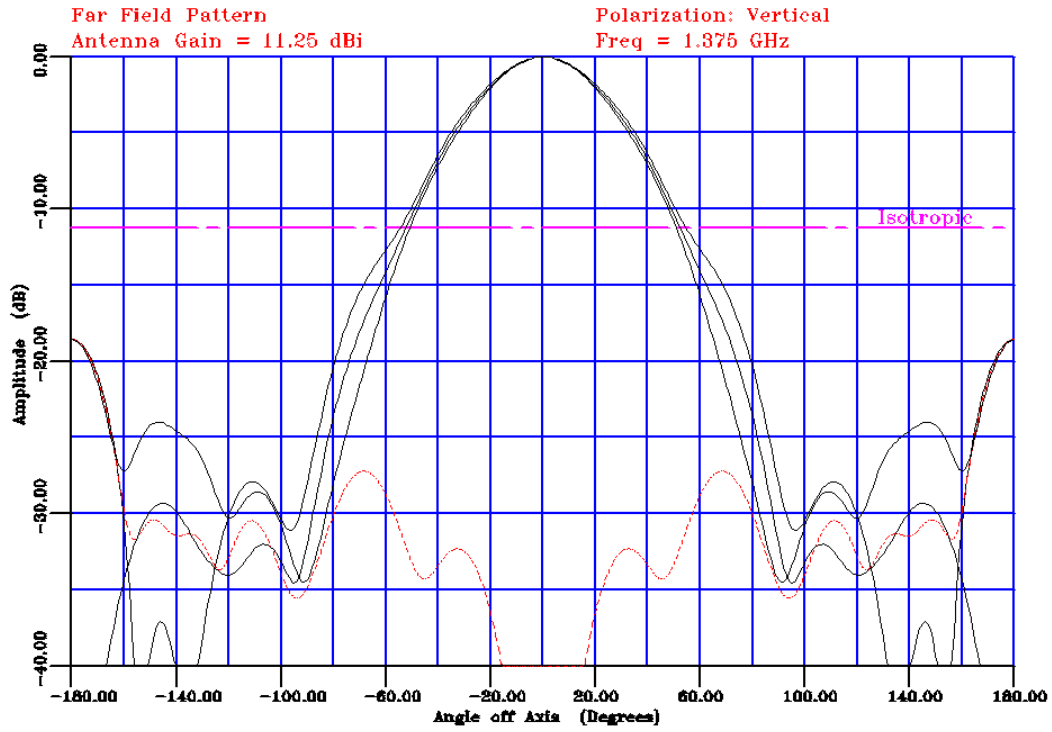
Far Field Pattern  
Antenna Gain = 10.53 dBi

Polarization: Vertical  
Freq = 1.225 GHz



**Figure A.13 TE<sub>11</sub> Mode Horn (26.0 cm diam) Radiation Pattern at 1.225 GHz**

TE<sub>11</sub> Mode Horn, 26.0cm Aperture, Optimized



TE<sub>11</sub> Mode Horn, 26.0cm Aperture, Optimized

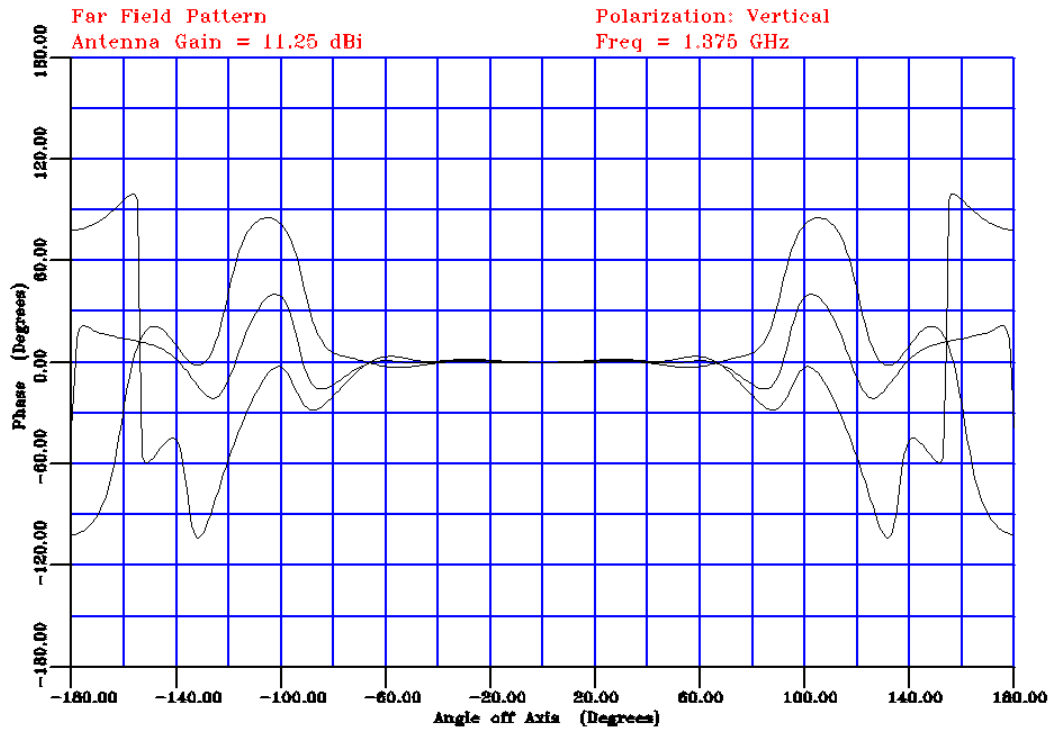


Figure A.14 TE<sub>11</sub> Mode Horn (26.0 cm diam) Radiation Pattern at 1.375 GHz

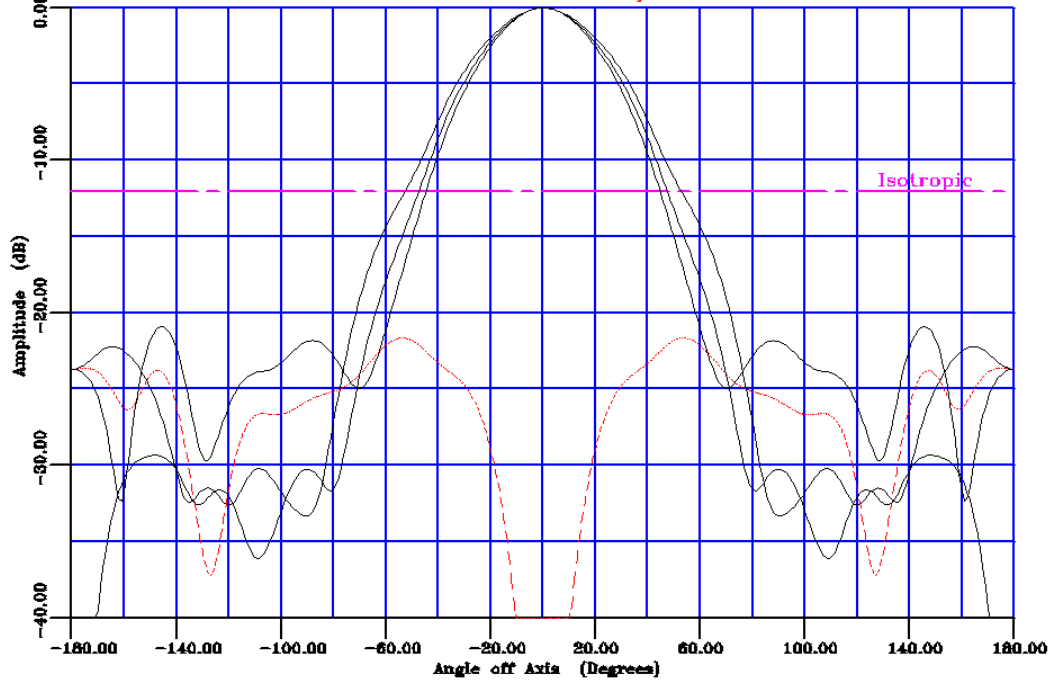
TE<sub>11</sub> Mode Horn, 26.0cm Aperture, Optimized

Far Field Pattern

Antenna Gain = 12.03 dBi

Polarization: Vertical

Freq = 1.525 GHz



TE<sub>11</sub> Mode Horn, 26.0cm Aperture, Optimized

Far Field Pattern

Antenna Gain = 12.03 dBi

Polarization: Vertical

Freq = 1.525 GHz

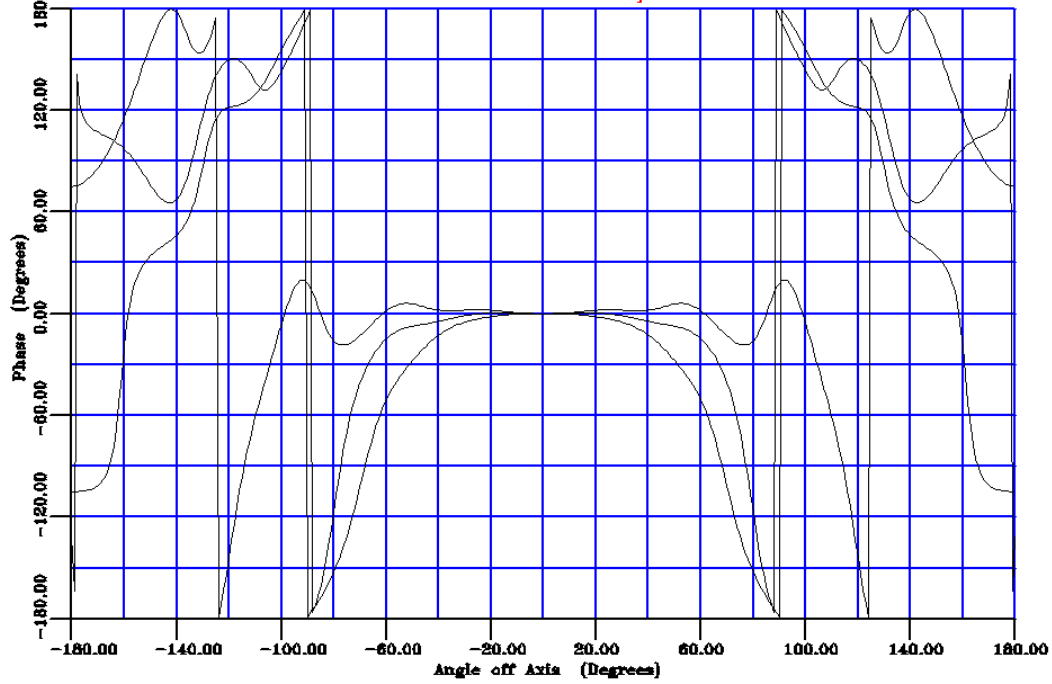


Figure A.15 TE<sub>11</sub> Mode Horn (26.0 cm diam) Radiation Pattern at 1.525 GHz

NAIC