

# ALFA IF/LO System

Lisa Wray  
Edgar Castro

Electronics División

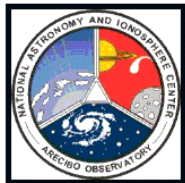

ALFA IF/LO System

ALFA Galactic Consortium March 2003

# ALFA Receiver System

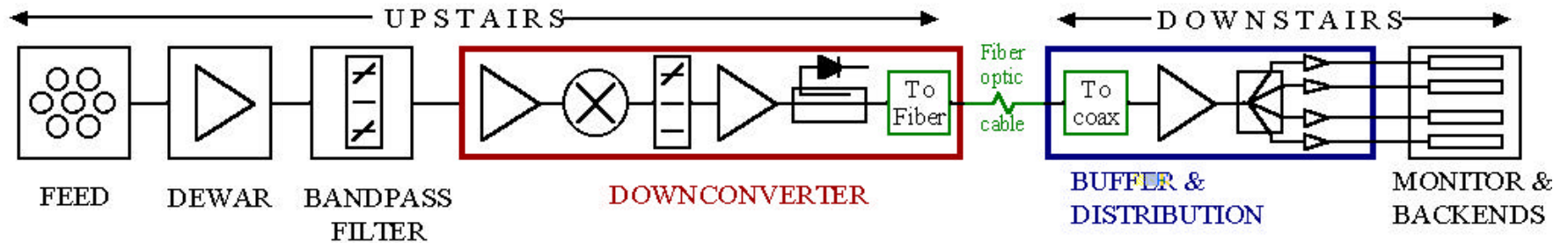

## Front End

- 7 element feed array
- correl available
- 40 dB gain
- Bandpass filter module

## Downconverter

- Single frequency downconversion
- RF: 1225-1525 MHz
- IF: 150-450 MHz
- Power monitor
- Fiber optic converter

## Buffer & Distribution

- Divide signal to accommodate  $n$  backends simultaneously
- Goal: High isolation between backends and monitor



ALFA IF/LO System

ALFA Galactic Consortium March 2003

# Downconverter

upstairs, after dewar and bandpass filter module

- Single mixer conversion
- RF = 1225 to 1525 MHz, IF = 150-450 MHz
- LO either high-side: 1375+300 or low side: 1375-300
- 34 dB gain
- 58 dB dynamic range, limited by noise floor of fiber transmitter on low end (-45 dBm) and compression of fiber transmitter on high end (+13 dBm)

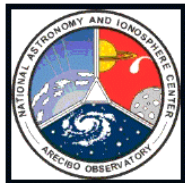
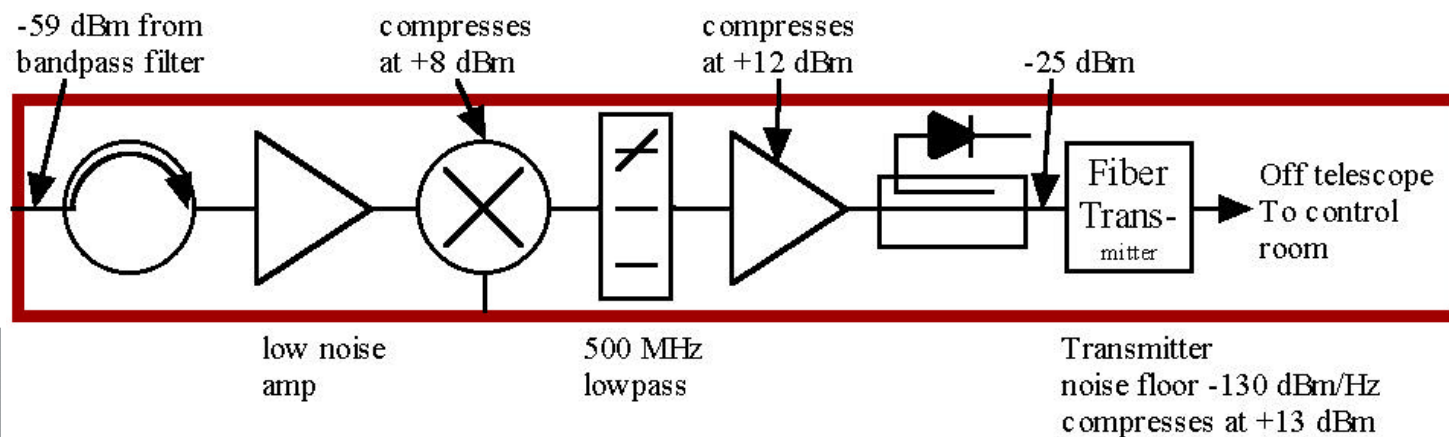

ALFA IF/LO System

ALFA Galactic Consortium March 2003

# More Downconverter Info

upstairs, after dewar and bandpass filter module

- Measured  $T_{\text{eff}} = 750\text{K}$   
(contributes  $.075\text{K}$  to  $T_{\text{sys}}$ )
- Anacom fiber optic transmitter:  $-130\text{dBm/Hz}$  noise floor ( $-43\text{ dBm}$  for  $500\text{ MHz}$ )
- Fiber link is low-loss
- Small light-weight surface mount design

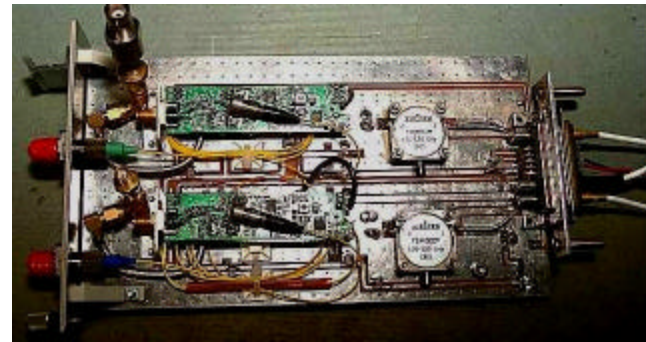

- Modular card cage



ALFA IF/LO System

ALFA Galactic Consortium March 2003

# Buffer + Distribution

Downstairs

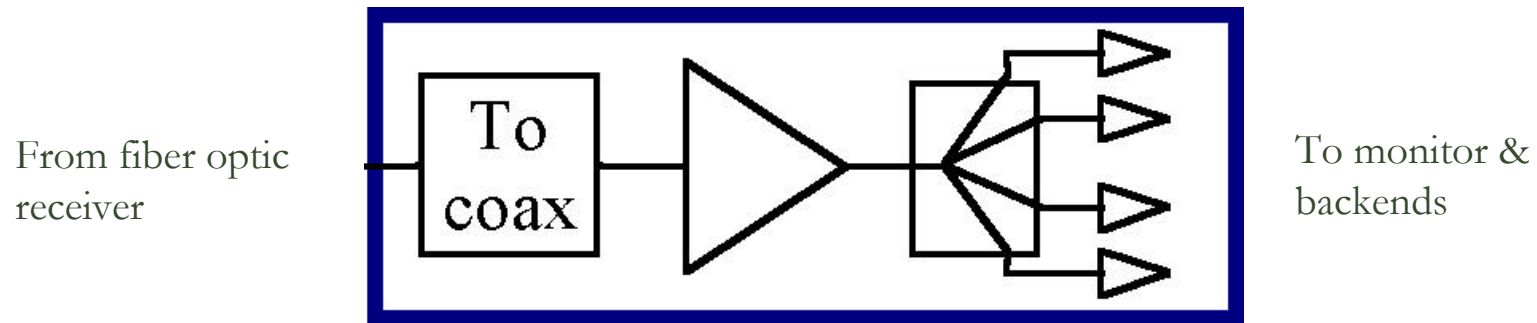

- Receive signals from fiber optic cable, put on coax
- Provide enough buffering to isolate backends
- Provide distribution network for backends
- Monitoring: one path dedicated to monitoring



ALFA IF/LO System

ALFA Galactic Consortium March 2003

# More on Buffer + Distribution

- Divide signal to accommodate  $n$  backends ... how many?
  - WAPP is the dedicated backend
  - Others: Pulsar, Extragalactic, Galactic, SETI
- Monitor
  - 14 IFs brought out to control room
  - Slow sample (fixed tau) and record for debugging/  
problem solving

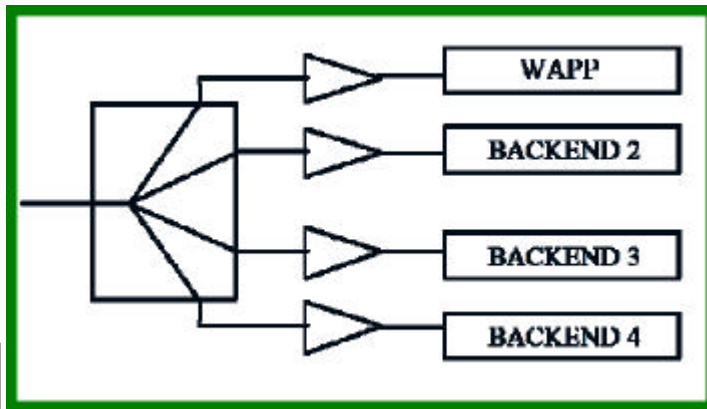

ALFA IF/LO System

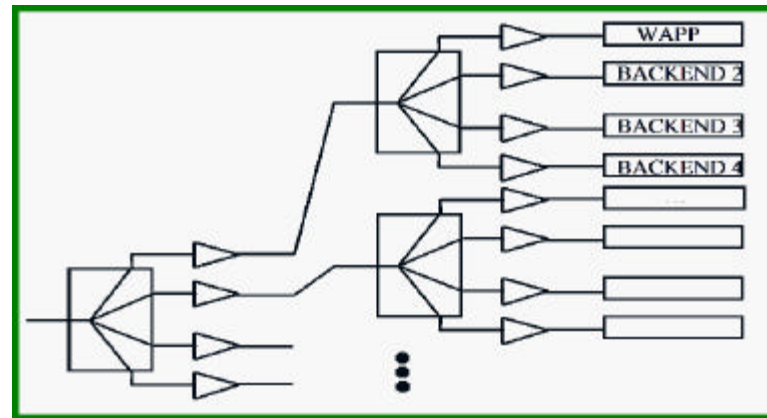

ALFA Galactic Consortium March 2003



# Acknowledgements

- Bill Sisk
- Ganesh
- Dudes in receiver section



ALFA IF/LO System

ALFA Galactic Consortium March 2003