

GALFA SPECTROMETER

Section I	Introduction to ALFA and GALFA	Page
Section II	System Description	1
Section III	System Specifications	1
		2

Section I: ALFA and GALFA Introduction

The Arecibo L-band Feed Array (ALFA) is a multibeam receiver designed to provide its users with a capability to survey the sky rapidly. It is inherently a high throughput device, meaning that astronomical data are acquired rapidly at the same time that areas on the sky are surveyed rapidly. The output of the ALFA receivers are processed in special-purpose signal processors for the specific research objectives of its users. As an astronomical research system, ALFA consists of the frontend receiver that is mounted on the telescope, a signal transmission system bringing data from the receiver and the control room, and the backend signal processing instrumentation located in the control room.

At the NAIC, the ALFA Project is organized around three topical science groups or consortia of interested scientists. One of these consortia is the group seeking to survey the neutral atomic hydrogen in the Milky Way Galaxy. This Galactic ALFA consortium, or GALFA consortium, derives its scientific objectives from accurate spectral measurements of the kinematic shape of the hydrogen line. The spectral decomposition of the hydrogen radio-frequency line observed with ALFA is done by a special-purpose backend signal processor known as a spectrometer. The radio spectrum is analyzed digitally by the spectrometer and presented to the astronomer for scientific analysis.

The GALFA spectrometer is designed around the scientific requirements necessary for the study of hydrogen gas in our galaxy. Other spectrometers are being designed and fabricated for SETI and the specific scientific requirements of the two other ALFA consortia, the consortium interested in galaxies beyond the Milky Way, and the consortium interested in studying pulsars.

A detailed research plan and list of all GALFA consortia members is available at

http://alfa.naic.edu/galactic/alfa_galactic.html

Section II: System Description

ALFA receives 7 beams, 2 polarizations per beam, each covering 1225-1525 MHz. The 14 IF signals cover nominally the 100 to 400 MHz band. Each IF signal will be split and sent to several backends for commensal observing; one of these backends will be dedicated for GALFA.

Two spectrometers pipelines are required for on each of the 14 IF signals:

- A high-resolution, low-bandwidth spectrometer (8K channels covering a 7 MHz bandwidth)
- A low-resolution, wide-bandwidth spectrometer (256 channels covering 100MHz)

The wide bandwidth spectrometer is needed to accurately measure and model standing waves so that these corrugations can later be removed from the high resolution spectra. (see Heiles, 2003Nov25, "Good news on using Fourier Filtering for Standing Wave Removal", ALFA memo series).

The GALFA spectrometer consists of:

- (14) Channel IF to quadrature baseband downconverter
- (7) Dual polarization spectrometer boards
- CompactPCI Computer Board
- Agilent 8648A synthesizer (controlled with an Ethernet to GPIB link)
- Uninterruptible power supply

Section III: System Specification

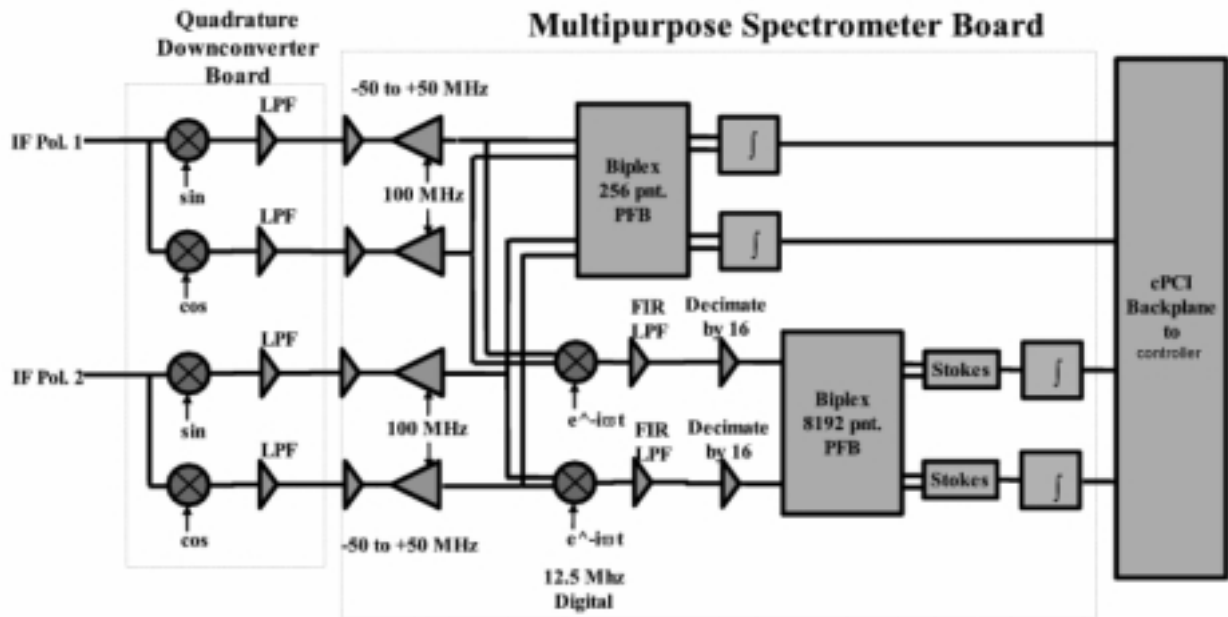

Figure 1: GALFA Spectrometer block diagram for one of seven identical beams

A block diagram of one of the seven GALFA beams is shown in Figure 1. First, each polarization's IF signal is downconverted to baseband via a pair of mixers and a pair of 40 MHz low-pass filters (corresponding to 100 MHz maximum-bandwidth operation, of which 80 to 90 MHz is usable bandwidth, due to low-pass filter roll off). The quadrature baseband signals are then amplified and sent to the spectrometer boards. The frequency synthesizer/LO is split to drive the 28 mixers (7 beams x 2 polarizations x 2 mixers/baseband).

Each spectrometer board handles two polarizations from one telescope beam. The baseband signals are to be digitized by four 8-bit ADC's at 100 Msamples/sec.

The digitized data is sent to two spectrometers, both realized in a single FPGA chip. The wideband spectrometer breaks the 100 MHz band into 256 channels by means of dual 256-channel polyphase filter banks, followed by detection and integration.

The narrowband spectrometer uses a programmable digital LO, digital complex mixers and FIR filters to select the sub-band. The narrowband spectrometer analyzes a 7 MHz sub-band (actually 100/14 MHz) , and outputs spectra with 8192 channels covering the sub-band. Note that Figure 1 incorrectly shows a decimation of 16 (the actual decimation is 14) and shows Stokes parameters (the spectrometer does not calculate stokes parameters).

Both wide- and narrowband spectra are output at a rate of 1 Hz to a general-purpose computer or file server for archiving and subsequent analysis.

Analog Inputs:

- 14 analog IF inputs.
- The quadrature baseband outputs from the downconverter feed:
28 8-bit 100 MHz ADC inputs (7 beams, two polarizations, I and Q inputs)

Outputs:

- Narrowband: 8192 channels x 2 polarizations x 32-bit powers
- Wideband: 256 channels x 2 polar x 32-bit powers
- Spectra are read out every second to the computer.
- Read out time: < 10 ms for all 7 beams (for GALFA applications) (< 1% dead time)
- Note the output data rate is roughly 0.5 MByte/sec (~2 GByte/hour)

Bandwidth:

- Wideband: BW_wide = 100 MHz bandwidth
- Narrowband: BW_wide/14

Polyphase Filter Bank:

- 4 times overlap (superb channel-to-channel isolation)
- Hanning x ($\frac{\sin x}{x}$) window

Digital I/O:

- External 100 MHz clock and 1 PPS sync (to provide synchronization between beams)
- 176 I/Os for optional off-board ADCs and/or ultra-fast readout
- Maximum bandwidth is 10 Gbit/sec (needed for some pulsar applications)

Integration Time:

- 1 second
- Integrations can be made longer by adding spectra together in software.

Arithmetic:

- 18-bit real, 18-bit imaginary
- Optional shifting at each stage
- Overflow detection at each stage
- 40-bit accumulators

Operating System:

- GNU/Linux